

AS3649

2500mA High Current LED Flash Driver

1 General Description

The AS3649 is an inductive high efficient DCDC step up converter with two current sources. The DCDC step up converter operates at a fixed frequency of 4MHz and includes soft startup to allow easy integration into noise sensitive RF systems. The two current sources can operate in flash / torch or video light modes.

The AS3649 includes flash timeout, overvoltage, overtemperature, undervoltage and LED short/open circuit protection functions. A TXMASK/TORCH function reduces the flash current in case of parallel operation to the RF power amplifier and avoids a system shutdown. Alternatively this pin can be used to directly operate the torch light directly. If the TXMask function is not used, it can be used as a hardware torch input (programmable).

A hardware NTC pin can be used to measure the LED temperature with the ADC and to automatically reduce the LED current if a temperature threshold is exceeded.

The AS3649 is controlled by an I²C interface and has a hardware reset pin ON. Setting ON=0 resets the AS3649. Interface input voltage levels are 1.8V compliant.

The AS3649 is available in a space-saving WL-CSP package measuring only 2.06x2.02x0.6mm and operates over the -30°C to +85°C temperature range.

2 Key Features

- High efficiency 4MHz fixed frequency DCDC Boost converter with soft start allows small coils
 - Stable even in coil current limit
- LED current adjustable up to 2x1000mA(2x1250mA with current boost) or 2000mA and automatic load balancing for two LEDs
- Automatic current adjustment for low battery voltage
- PWM operation for lower output current for reliable light output of the LED; can run at 31.5kHz to avoid audible noise
- Protection functions:
 - Automatic Flash Timeout timer to protect the LED(s)
 - Overvoltage and undervoltage Protection
 - Overtemperature Protection
 - LED short/open circuit protection
- ADC to measure LED temperature
- NTC to automatically reduce the flash current if the LED temperature is too high (programmable level)
- I²C Interface with hardware reset pin
- Available in tiny WL-CSP Package, 16 balls 0.5mm pitch, 2.06x2.02x0.6mm package size

3 Applications

Flash/Torch for mobile phones

Figure 1. Typical Operating Circuit

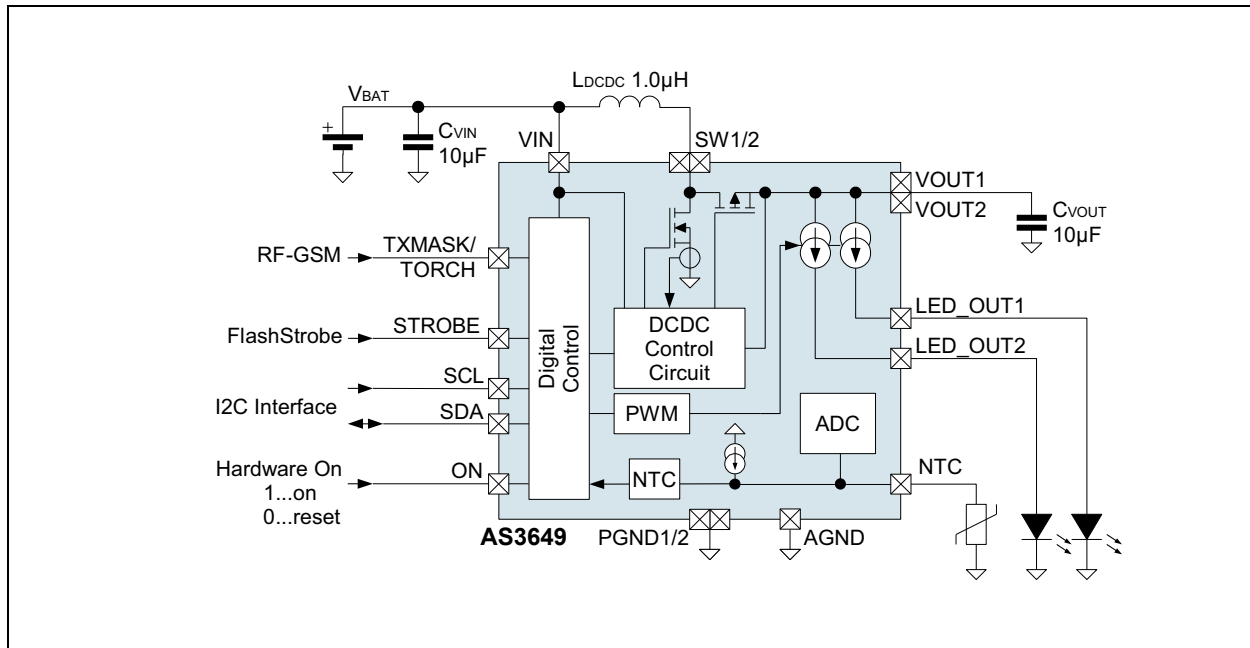



4 Pin Assignments

Figure 2. Pin Assignments (Top View)

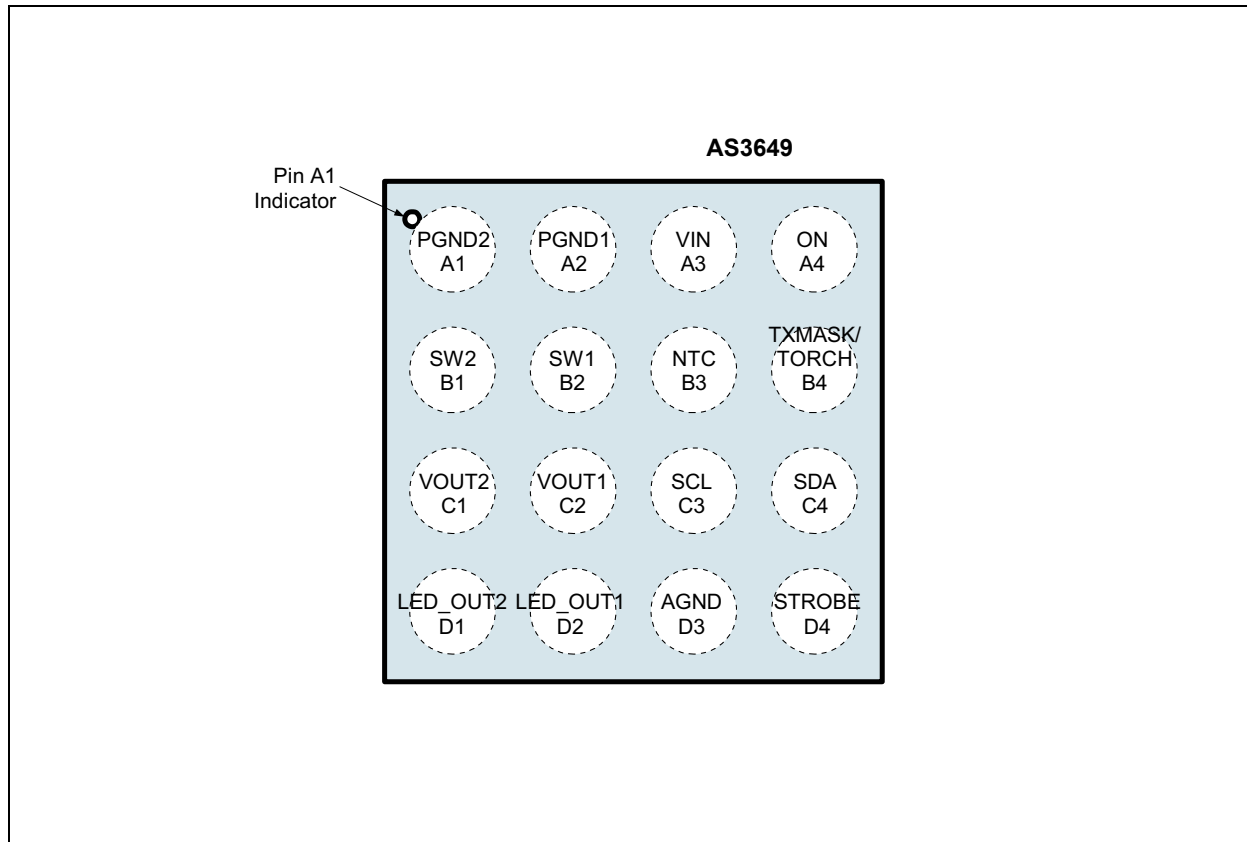

4.1 Pin Description

Table 1. Pin Description for AS3649

Pin Number ¹	Pin Name	Description
A1	PGND2	Power ground; make a short connection between all GND balls
A2	PGND1	Power ground; make a short connection between all GND balls
A3	VIN	Positive supply voltage input - connect to supply and make a short connection to input capacitor CVIN and to coil LDCDC
A4	ON	Hardware reset input; an active low signal resets the registers of AS3649 and enters shutdown (and I ² C lines SDA and SCL are in high-Z), active high allows to operate the device
B1	SW2	DCDC converter switching node - make a short connection to SW1 / coil LDCDC
B2	SW1	DCDC converter switching node - make a short connection to SW2 / coil LDCDC
B3	NTC	LED temperature sensor input (NTC) for LED overtemperature protection
B4	TXMASK/TORCH	Function 1: Connect to RF power amplifier enable signal - reduces currents during flash to avoid a system shutdown due to parallel operation of the RF PA and the flash driver Function 2: Operate torch current level without using the I ² C interface to operate the torch without need to start a camera processor (if the I ² C is connected to the camera processor)
C1	VOUT2	DCDC converter output capacitor - make a short connection to CVOUT / VOUT1
C2	VOUT1	DCDC converter output capacitor - make a short connection to CVOUT / VOUT2



Table 1. Pin Description for AS3649

Pin Number ¹	Pin Name	Description
C3	SCL	serial clock input for I ² C interface
C4	SDA	serial data input/output for I ² C interface (needs external pullup resistor)
D1	LED_OUT2	Flash LED current source
D2	LED_OUT1	Flash LED current source
D3	AGND	Analog ground; make a short connection between all GND balls
D4	STROBE	Digital input with pulldown to control strobe time for flash function

1. Final pinout subject to change - now only used to count number of pins



5 Absolute Maximum Ratings

Stresses beyond those listed in [Table 2](#) may cause permanent damage to the device. These are stress ratings only, and functional operation of the device at these or any other conditions beyond those indicated in [Electrical Characteristics on page 5](#) is not implied. Exposure to absolute maximum rating conditions for extended periods may affect device reliability.

Table 2. Absolute Maximum Ratings

Parameter	Min	Max	Units	Comments
VIN to GND	-0.3	+7.0	V	
STROBE, TXMASK/TORCH, SCL, SDA, ON, NTC to GND	-0.3	VIN + 0.3	V	max. +7V
SW1/2, VOUT1/2, LED_OUT1/2 to GND	-0.3	+7.0	V	
VOUT1/2 to SW1/2	-0.3		V	Note: Diode between VOUT1/2 and SW1/2
voltage between AGND, PGND1/2 pins	0.0	0.0	V	short connection required
Input Pin Current without causing latching	-100	+100 +IIN	mA	Norm: EIA/JESD78
Continuous Power Dissipation (TA = +70°C)				
Continuous power dissipation		1470	mW	PT at 70°C ¹
Continuous power dissipation derating factor		20	mW/°C	PDERATE ²
Electrostatic Discharge				
ESD HBM		±2000	V	Norm: JEDEC JESD22-A114F
ESD CDM		±500	V	Norm: JEDEC JESD 22-C101E
Temperature Ranges and Storage Conditions				
Junction to ambient thermal resistance		50 ³	°C/W	For more information about thermal metrics, see application note AN01 Thermal Characteristics
Junction Temperature		+150	°C	Internally limited (overtemperature protection), max. 20000s
Storage Temperature Range	-55	+125	°C	
Humidity	5	85	%	Non condensing
Body Temperature during Soldering		+260	°C	according to IPC/JEDEC J-STD-020
Moisture Sensitivity Level (MSL)	MSL 1			Represents a max. floor life time of unlimited

1. Depending on actual PCB layout and PCB used measured on demoboard; for peak power dissipation during flashing see document 'AS3649 Thermal Measurements'
2. PDERATE derating factor changes the total continuous power dissipation (PT) if the ambient temperature is not 70°C. Therefore for e.g. TAMB=85°C calculate PT at 85°C = PT - PDERATE * (85°C - 70°C)
3. Measured on AS3649 demoboard.



6 Electrical Characteristics

V_{VIN} = +2.7V to +4.4V, T_{AMB} = -30°C to +85°C, unless otherwise specified. Typical values are at V_{VIN} = +3.7V, T_{AMB} = +25°C, unless otherwise specified.

Table 3. Electrical Characteristics

Symbol	Parameter	Condition	Min	Typ	Max	Unit	
General Operating Conditions							
V _{VIN}	Supply Voltage	Pin VIN	2.7	3.7	4.4	V	
V _{VINREDUCED_FUNC}	Supply Voltage	AS3649 functionally working, but not all parameters fulfilled	2.5 4.4		2.7 5.5	V	
ISHUTDOWN	Shutdown Current	TXMASK/TORCH=L, STROBE=L, ON=L, V _{VIN} <3.7V		1.0	2.0	μA	
I _{STANBY}	Standby Current	Interface active, TXMASK/TORCH=L, STROBE=L V _{VIN} <3.7V		1.0	10	μA	
T _{AMB}	Operating Temperature		-30	25	85	°C	
η ¹	Application Efficiency (DCDC and current source)	L _{COIL} =0.6μH@3A, L _{ESR} =60mΩ, I _{LED_OUT1,2} =2000mA, t _{FLASH} <300ms, V _{FLED} =3.7V		83		%	
t _{FLASH}	Flash Duration	V _{VIN} >3.3V, T _{AMB} <85°C, I _{LED_OUT} <2000mA If T _{AMB} or I _{LED_OUT} is reduced or V _{VIN} is increased, longer flash times are allowed. For longer flash durations, see section Current Reduction by VIN Measurements in Flash Mode and Diagnostic Pulse on page 15			300	ms	
DCDC Step Up Converter							
V _{VOUT}	DCDC Boost output Voltage (pin V _{OUT1/2})		2.8		5.5	V	
R _{PMOS}	On-resistance	DCDC internal PMOS switch		45		mΩ	
R _{NMOS}	On-resistance	DCDC internal NMOS switch		47		mΩ	
f _{CLK}	Operating Frequency	All internal timings are derived from this oscillator	-7.5%	4.0	+7.5%	MHz	
V _{VOUT5V}	DCDC Boost output Voltage (pin V _{OUT1/2})	Constant voltage mode operation const_v_mode (see page 30)=1		5.0		V	
Current Sources							
V _{LED}	LED forward voltage	Two flash LEDs, I _{LED_OUT} <2x1000mA	2.8	3.32	4.0	V	
		Single flash LED, I _{LED_OUT} <1800mA	2.8	3.32	4.4	V	
I _{LED_OUT}	LED_OUT1/2 current combined	V _{VIN} >3.3V, coil_peak=11b, L _{COIL} =0.6μH@3.4A, L _{ESR} =60mΩ, coil SPM3012T-1R0M, t _{FLASH} <300ms	dual flash LED, current_boost =0	0		2000	mA
			single flash LED	0		2000	mA
I _{LED_OUT_BOOST}	LED_OUT1/2 current combined	Dual flash LED, current_boost =1	0		2500 ²	mA	
I _{LED_OUTΔ}	LED_OUT1/2 current source accuracy	Otherwise	-7		+7	%	
		I _{LED_OUT} =500mA...800mA, 0°C<T _J <100°C	-5		+5	%	
I _{LED_OUT_RAMP}	LED_OUT1/2 ramp time	Rampup initiated by I ² C command		730		μs	
		Rampup started by STROBE		530		μs	
		Full range Ramp-down		500		μs	
I _{LED_OUT_RIPPLE}	LED_OUT current ripple	I _{LED_OUT} = 1000mA		40		mAPP	



Table 3. Electrical Characteristics (Continued)

Symbol	Parameter	Condition	Min	Typ	Max	Unit	
VILED_COMP	LED_OUT current source voltage compliance	Minimum voltage between pin VOUT1/2 and LED_OUT1/2 for operation of the current source with <code>current_boost=0</code>		230		mV	
VILED_COMP_BOOST		VILED_COMP with <code>current_boost=1</code>		290		mV	
LLED_CONNECTION	LED connection inductance	Represents a maximum connection length of 10cm (LED connection and ground return path)			100	nH	
Protection and Fault Detection Functions (see page 12)							
VVOUTMAX	VVOUT overvoltage protection	DCDC Converter Overvoltage Protection	5.0	5.3	5.6	V	
ILIMIT	Current Limit for coil LDCDC (Pin SW) measured at 25% PWM duty cycle ³ maximum 40000s lifetime operation in overcurrent limit	<code>coil_peak=00b</code>	2.25	2.5	2.75	A	
		<code>coil_peak=01b</code>	2.61	2.9	3.19		
		Default value <code>coil_peak (see page 23)=10b</code>	3.0	3.3	3.63		
		<code>coil_peak=11b</code>	3.3	3.7	4.1		
VLEDSHORT	Flash LED short circuit detection voltage	Voltage measured between pins LED_OUT1,2 and GND		1.2		V	
TOVTEMP	Overtemperature Protection	Junction temperature		144		°C	
TOVTEMPHYS T	Overtemperature Hysteresis			5		°C	
tFLASHTIMEOUT	Flash Timeout Timer	Can be adjusted with register <code>flash_timeout</code> (page 26)	4		1124	ms	
		Accuracy	-7.5		+7.5	%	
VVULO	Undervoltage Lockout	Falling VVIN	2.25	2.4	2.5	V	
		Rising VVIN	VVULO+0.05	VVULO+0.1	VVULO+0.15	V	
VIN_LOW_VOLTAGE	Battery Low Voltage Protection	Defined by <code>vin_low_v</code> - see Current Reduction by VIN Measurements in Flash Mode and Diagnostic Pulse on page 15	-2.5%	3.0-3.47	+2.5%	V	
Protection and Fault Detection Functions - NTC							
INTC	NTC Current Source	Adjustable by <code>ntc_current</code> (page 25) in 40µA steps	Range	40		600	µA
			ΔI - accuracy $V(NTC) \leq 1.7V$	-7		+7	% ⁴
				-5		+5	µA
VNTC_TH	Threshold for overtemperature	If <code>ntc_on</code> (page 25)=1 and the voltage on NTC drops below VNTC_TH, any flash/torch or pwm operation of LED_OUT is stopped		1.0		V	
ADC							
Resolution				10		bits	
Range	ADC input range; channel selected by <code>adc_channel</code> (page 27)	ADC Code	0		full scale		
		NTC	0.0		2.2	V	
		VIN	0.0		5.5	V	
		TJUNC (AS3649 junction temperature)			see Table 6	°C	
Accuracy	ADC measurement accuracy	NTC	-1.5		+1.5	% full scale	
		TJUNC (-30°C...150°C)	-8		+8	°C	
		TJUNC (0°C...85°C)	-5		+5	°C	



Table 3. Electrical Characteristics (Continued)

Symbol	Parameter	Condition	Min	Typ	Max	Unit
Digital Interface						
V _{IH}	High Level Input Voltage	Pins ON, SCL, SDA, and TXMASK/TORCH	1.26		V _{VIN}	V
V _{IL}	Low Level Input Voltage		0.0		0.54	V
V _{IHFLASH}	High Level Input Voltage	Pin STROBE.	0.84		V _{VIN}	V
V _{ILFLASH}	Low Level Input Voltage		0.0		0.54	V
V _{OL}	Low Level Output Voltage	Pin SDA, I _{OL} =3mA			0.3	V
I _{LEAK}	Leakage current	Pins ON, SCL, SDA	-1.0	0.0	+1.0	μA
I _{PD}	Pulldown current to GND ⁵	Pins STROBE and TXMASK/TORCH		36		μA
t _{DEBTORCH}	TORCH debounce time		6.3	9	11.7	ms
t _{DEBTXMASK}	TXMASK debounce timer			1.5		μs
I²C mode timings - see Figure 3 on page 8						
f _{SCLK}	SCL Clock Frequency		0		400	kHz
t _{BUF}	Bus Free Time Between a STOP and START Condition		1.3			μs
t _{HD:STA}	Hold Time (Repeated) START Condition ⁶		0.6			μs
t _{LOW}	LOW Period of SCL Clock		1.3			μs
t _{HIGH}	HIGH Period of SCL Clock		0.6			μs
t _{SU:STA}	Setup Time for a Repeated START Condition		0.6			μs
t _{HD:DAT}	Data Hold Time ⁷		0		0.9	μs
t _{SU:DAT}	Data Setup Time ⁸		100			ns
t _R	Rise Time of Both SDA and SCL Signals		20 + 0.1C _B		300	ns
t _F	Fall Time of Both SDA and SCL Signals		20 + 0.1C _B		300	ns
t _{SU:STO}	Setup Time for STOP Condition		0.6			μs
C _B	Capacitive Load for Each Bus Line	C _B — total capacitance of one bus line in pF			400	pF
C _{I/O}	I/O Capacitance (SDA, SCL)				10	pF

1. To improve efficiency at low output currents, the active part of the internal switching transistor PMOS is reduced in size to 1/5 its original size. This reduces the current required to drive the PMOS transistor and therefore improves overall efficiency at low output currents.
2. The maximum current driving capability depends on supply voltage V_{VIN}, LED forward voltage and coil peak current limit.
3. Due to slope compensation of the current limit, I_{LIMIT} changes with duty cycle - see Figure 16 on page 11.
4. Accuracy defined in % of current setting and in absolute value (μA), accuracy values have to be added together
5. A pulldown current of 36μA is equal to a pulldown resistor of 42kΩ at 1.5V
6. After this period, the first clock pulse is generated
7. A device must internally provide a hold time of at least 300ns for the SDA signal (referred to the V_{IHMIN} of the SCL signal) to bridge the undefined region of the falling edge of SCL.
8. A fast-mode device can be used in a standard-mode system, but the requirement t_{SU:DAT} = to 250ns must then be met. This is automatically the case if the device does not stretch the LOW period of the SCL signal. If such a device does stretch the LOW period of the SCL signal, it must output the next data bit to the SDA line t_R max + t_{SU:DAT} = 1000 + 250 = 1250ns before the SCL line is released.



6.1 Timing Diagrams

Figure 3. I^2C mode Timing Diagram

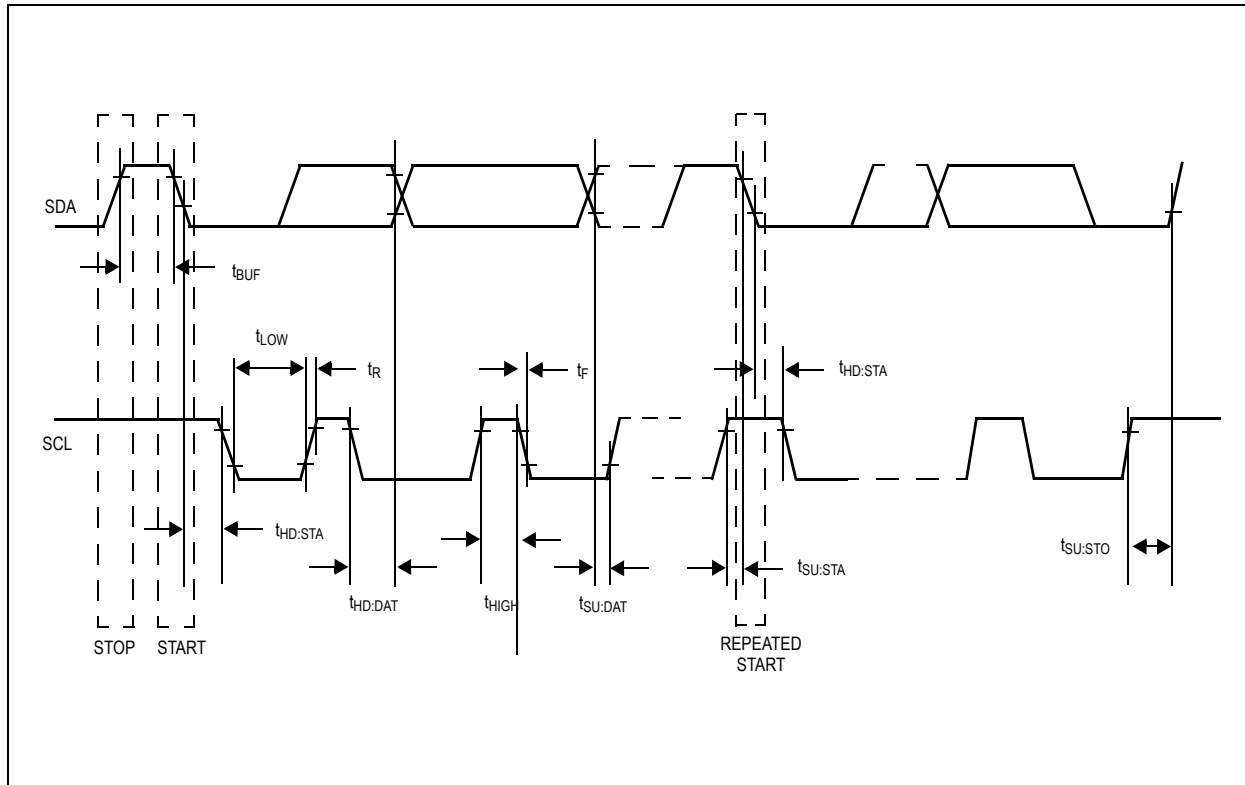



7 Typical Operating Characteristics

V_{IN} = 3.7V, T_A = +25°C (unless otherwise specified)

Figure 4. DCDC Efficiency vs. V_{VIN}

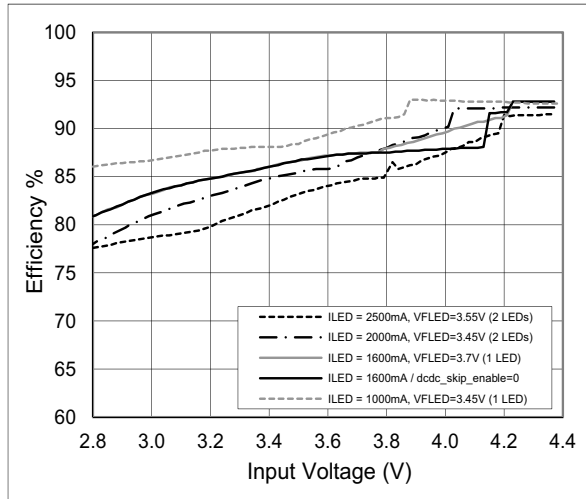

Figure 5. Application Efficiency (P_{LED}/P_{VIN}) vs. V_{VIN}

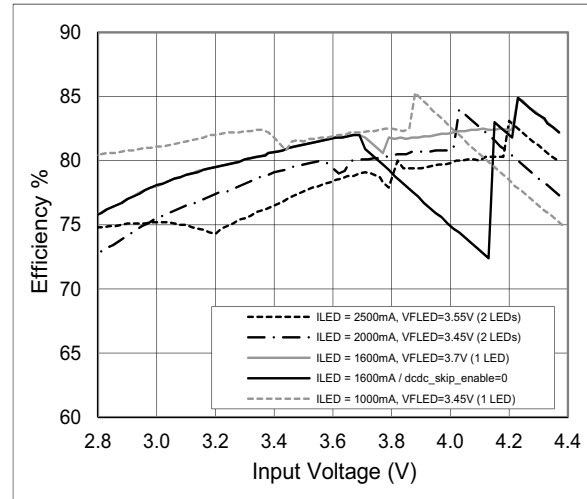

Figure 6. Battery Current vs. V_{VIN}

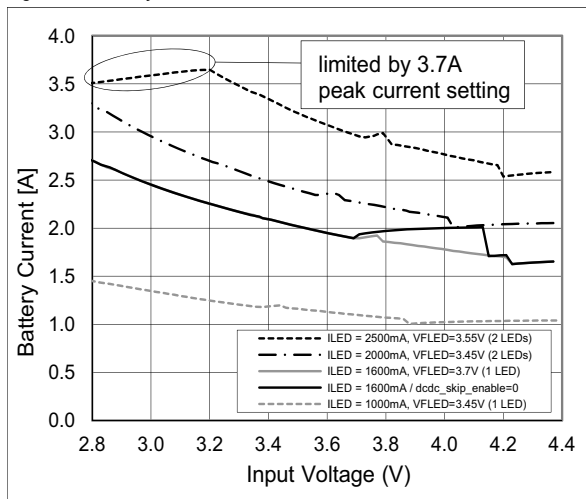

Figure 7. Efficiency at low currents (298mA/100mA)

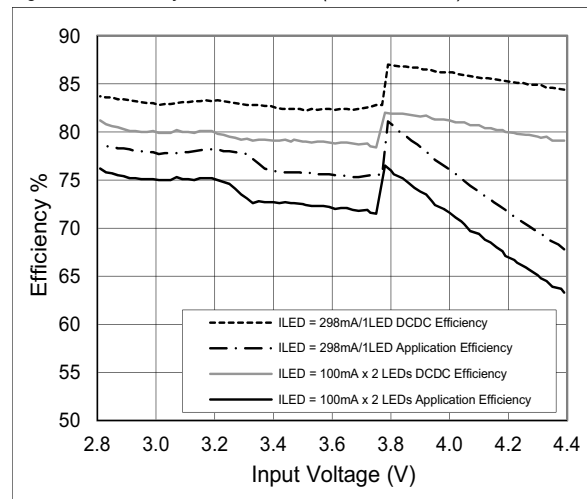

Figure 8. I_{LED} Startup (I_{LED_OUT}=1.0A)

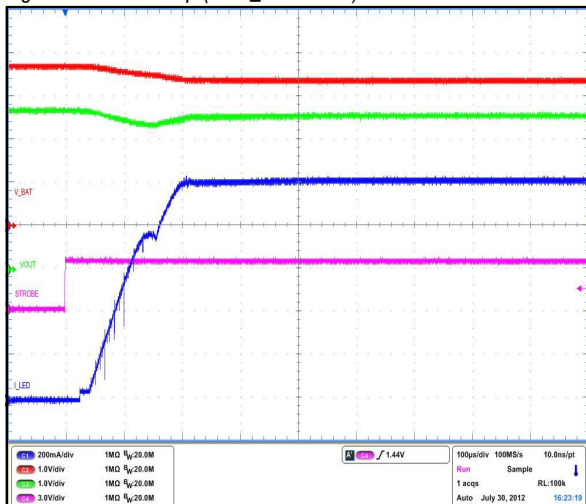

Figure 9. I_{VIN}, I_{LED} Startup (I_{LED_OUT}=800mA)

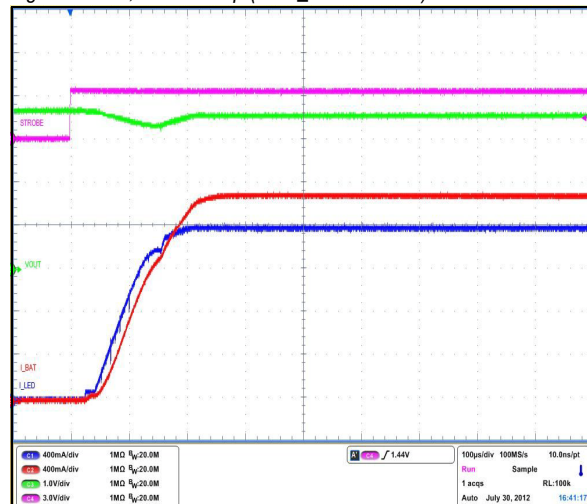



Figure 10. ILED vs. VVIN

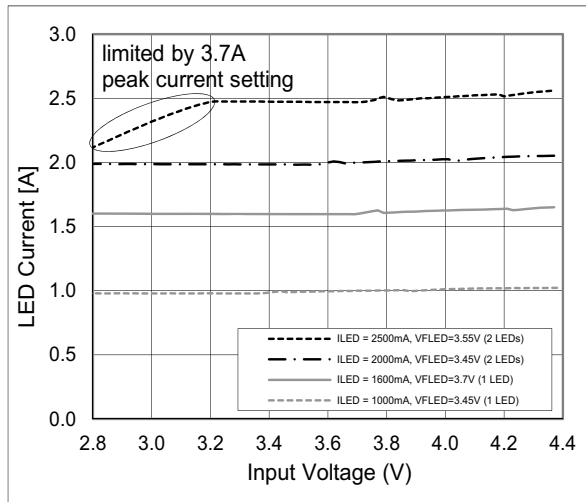

Figure 11. VOUT / ILED_OUT ripple, ILED_OUT = 2x1.0A

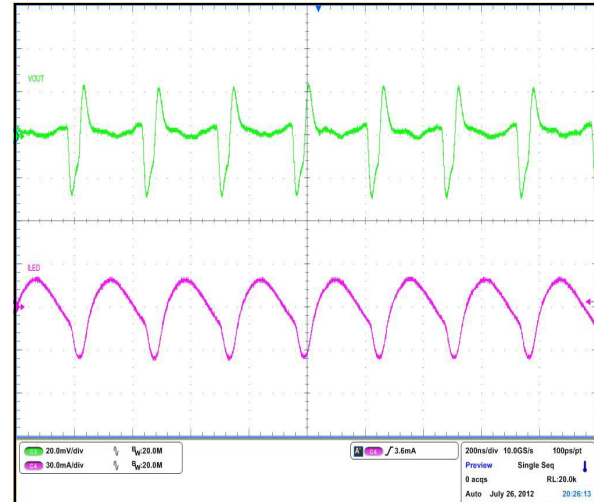

Figure 12. Diagnostic Pulse Operation

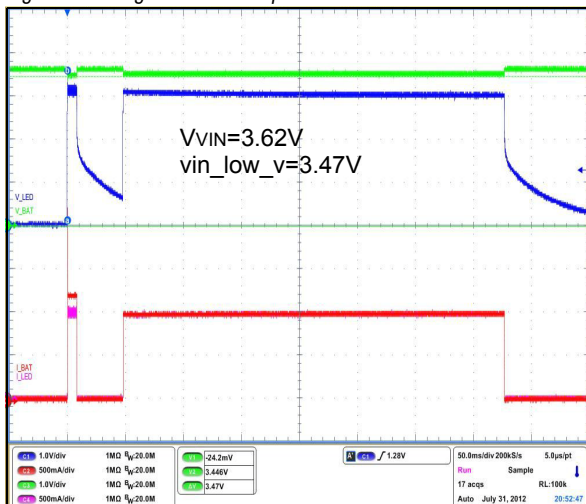

Figure 13. TxMask operation waveform (ILED, IVIN)

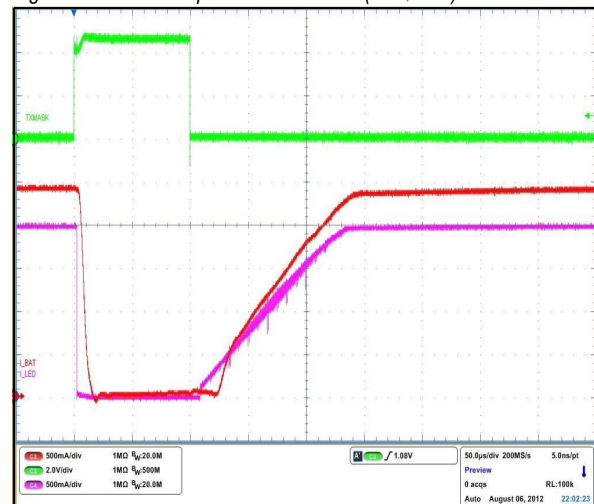

Figure 14. Timeout Timer

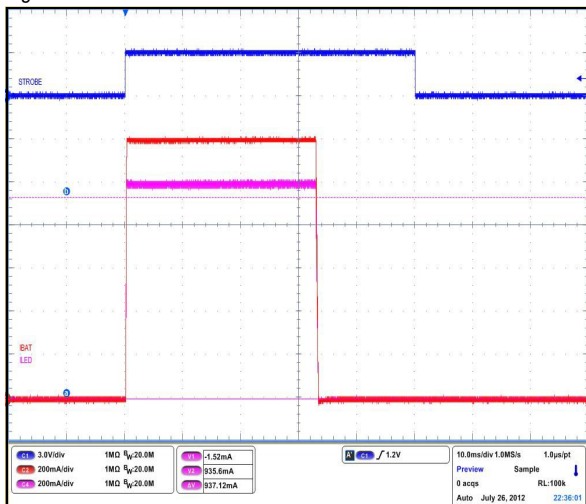
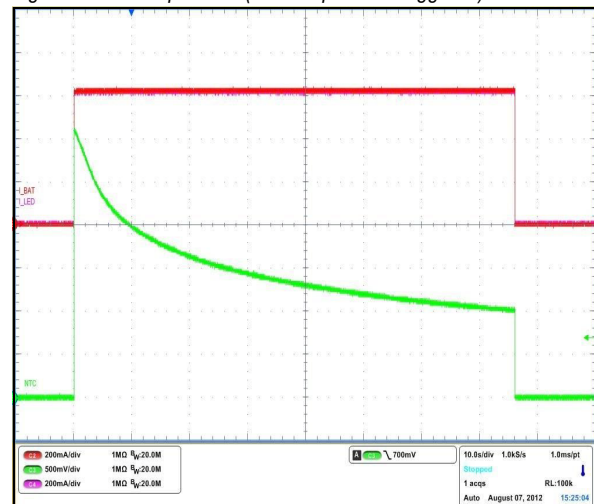

Figure 15. NTC operation (overtemperature triggered)





8 Detailed Description

The AS3649 is a high performance DCDC step up converter with internal PMOS and NMOS switches. Its output is connected to one or two flash LEDs¹ with two internal current sources and hardware LED temperature protection using an external NTC. The device is controlled by the pins SDA and SCL in I²C mode and includes a hardware reset input ON.

The actual operating mode like standby, torch light, indicator or flash mode, can then be chosen by the interface. If not in standby mode, the device automatically enters shutdown and resets all registers by setting pin ON=0.

The AS3649 includes a fixed frequency DCDC step-up with accurate startup control. Together with the current source (on LED_OUT1/2) it includes several protection and safety functions.

8.1 Internal Circuit Diagram

Figure 16. Internal Circuit Diagram

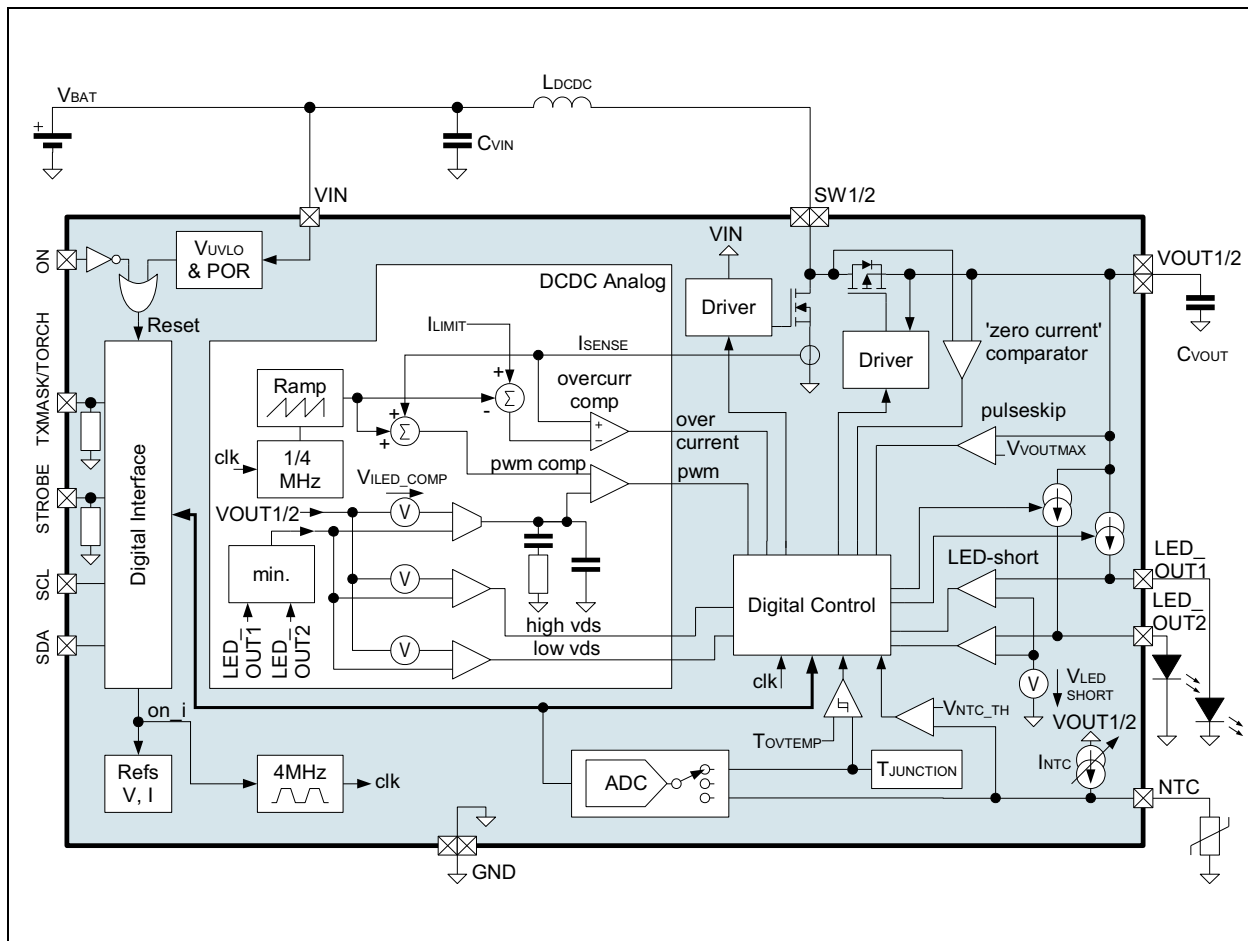

8.2 Softstart / Soft ramp down

During startup and ramp down the LED current is smoothly ramped up and ramped down. If the DCDC converter goes out of regulation (measured by monitoring the voltage across the current sources), the ramp up is temporarily stopped in order for the DCDC to return to regulation².

1. If two LEDs are connected, it is possible to operate each of the two LEDs individually as the LED current can be selected individually.
2. The actual value of the LED current setting can be readout by the register `led_current_actual` (see page 31) to allow the camera processor to adopt to the actual operating conditions.



8.3 4/1MHz Operating Mode Switching and Pulse Skipping

If `freq_switch_on` (see page 29)=1 and if `led_current1`>=40h³ or `led_current2`>=40h³ and `current_boost`=0, the DCDC converter always operates in PWM mode (exception: PFM mode is allowed during startup) to reduce EMI in EMI sensitive systems. For high duty cycles close to 100% on-time (maximum duty cycle) of the PMOS, the DCDC converter can switch into a 1MHz operating mode and maximum duty cycle to improve efficiency for this load condition⁴. The DCDC converter returns back to its normal 4MHz operating frequency when load or supply conditions change. Due to this switching between two fixed frequencies the noise spectrum of the system is exactly defined and predictable. If improved efficiency is required, the fixed switching between 4MHz / 1MHz can be disabled by `freq_switch_on` (see page 29)=0. In this case pulseskip will be used.

The modes are selected according to Table 4:

Table 4. 4/1MHz switching and pulseskip operating modes

<code>freq_switch_on</code>	<code>dcdc_skip_enable</code>	<code>led_current1</code> >=40h or <code>led_current2</code> >=40h	<code>led_current1</code> <40h and <code>led_current2</code> <40h
0	0	4MHz forced PWM operation (no 1MHz operation, no pulseskip)	
0	1	4MHz, pulse skipping allowed, no 1MHz operation	
1	0	4MHz/1MHz forced PWM operation, pulseskip not allowed ¹	4MHz forced PWM operation (no 1MHz operation, no pulseskip)
1	1		4MHz, pulse skipping allowed, no 1MHz operation

1. If `current_boost`=1, `freq_switch_on` is set to '0'.

The internal circuit for switching between these two frequencies is shown in Figure 17 (for simplicity only a single current source is shown):

Figure 17. Internal circuit of 4MHz/1MHz selection

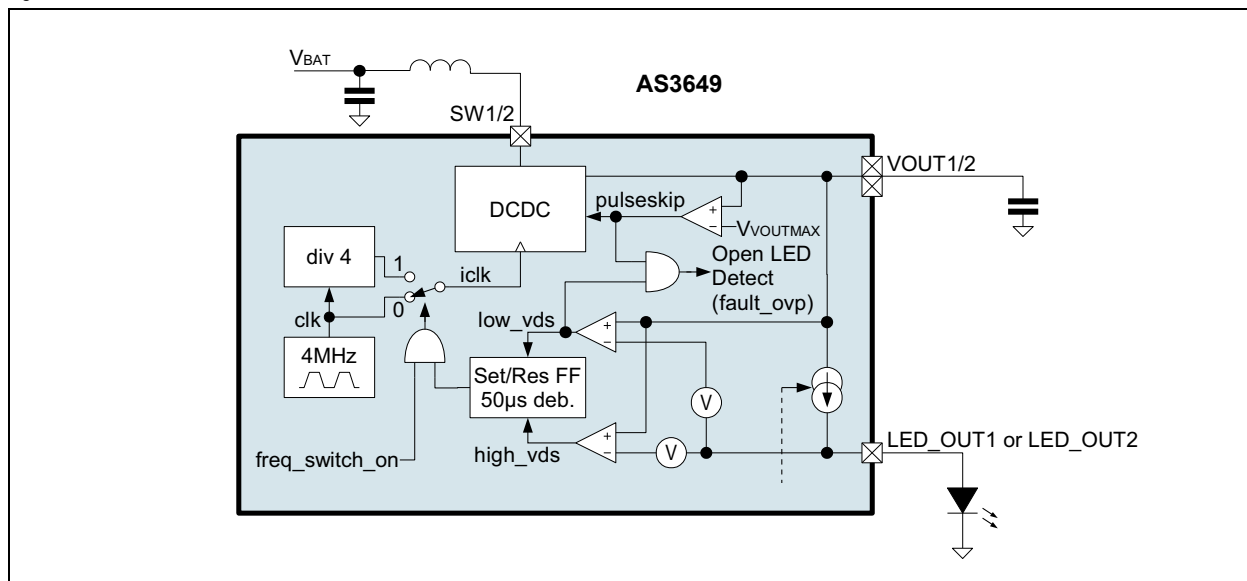

Note: If the voltage on VOUT1/2 exceeds VVOUTMAX, the DCDC will always skip pulses to limit the output voltage.

8.4 Protection and Fault Detection Functions

The protection functions protect the AS3649 and the LED(s) against physical damage. In most cases a `Fault` register bit is set, which can be readout by the I²C interface. The fault bits are automatically cleared by a I²C readout of the fault register. Additionally the DCDC is stopped and the current sources are disabled⁵ by resetting `mode_setting`=00⁶ and `txmask_torch_mode`=00.

3. Set register `dcdc_skip_enable` (see page 28)=1 if 4MHz forced operation shall be used below this LED current.
4. Efficiency compared to a 4MHz only DCDC converter forced to operate with minimum duty cycle.



8.4.1 Overvoltage Protection

In case of no or a broken LED(s) at the pin LED_OUT1/2 and an enabled DCDC converter, the voltage on VOUT1/2 rises until it reaches VVOUTMAX (overvoltage condition) and the voltage across the current source is below low_vds⁷, the DCDC converter is stopped, the current sources are disabled and the bit `fault_ovp` (see page 29)⁸ is set⁹. In a dual LED configuration for the AS3649, if a single open LED is detected, this LED is disabled, `fault_ovp` is set and the device continues operation with the other LED.

Note: In PWM operating mode (`mode_setting=01b`), open LED detection is disabled (and `fault_ovp` is not set). The output voltage will nevertheless be kept below VVOUTMAX.

8.4.2 Short Circuit Protection

After the startup of the DCDC converter, the voltage on LED_OUT1/2 is continuously monitored and compared against VLEDSHORT if the LED current is above 27.5mA (`current_boost=0`), 34.3mA (`current_boost=1`)^{10, 11} (see Figure 18). If the voltage on the LED ($V_{LED} = LED_OUT1/2$) stays below VLEDSHORT, the DCDC is stopped (as a shorted LED is assumed), the current sources are disabled and the bit `fault_led_short` (see page 29) is set. In a dual LED configuration for the AS3649, if a single shorted LED is detected, this LED is disabled, `fault_led_short` is set and the device continues operation with the other LED.

Note: In PWM operating mode (`mode_setting=01b`), short circuit protection is disabled.

Figure 18. Short LED Detection

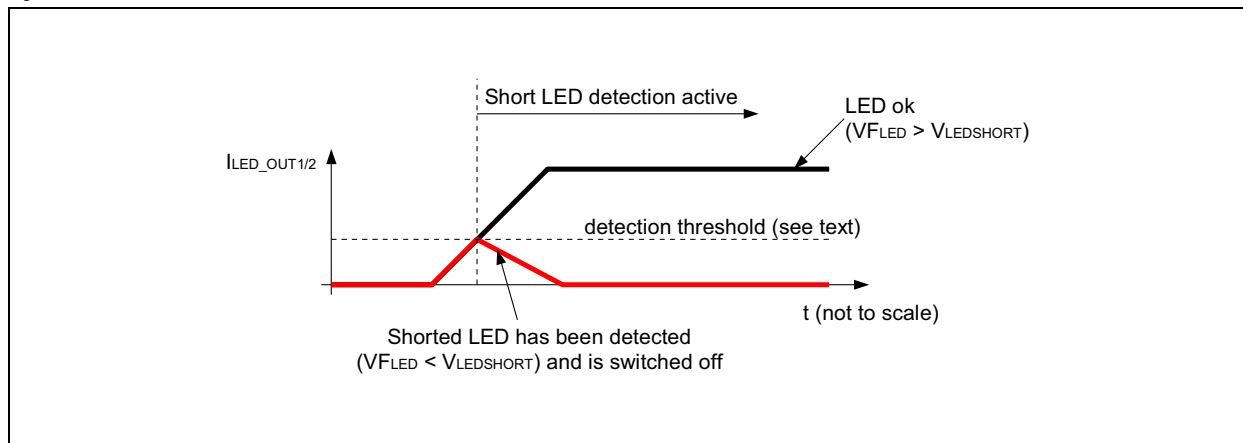

8.4.3 Overtemperature Protection

The junction temperature of the AS3649 is continuously monitored. If the temperature exceeds T_{OVTEMP} , the DCDC is stopped, the current sources are disabled (instantaneous) and the bit `fault_overtemp` (see page 29) is set (but the operating mode `mode_setting` is not changed). The driver is automatically re-enabled¹² once the junction temperature drops below $T_{OVTEMP}-T_{OVTEMPHYS}$.

8.4.4 TXMASK event occurred

If during flash, TXMASK current reduction is enabled (see TXMASK on page 15, configured by `txmask_torch_mode=01`) and a TXMASK event happened (pin TXMASK/TORCH=1), the fault register bit `fault_txmask` (see page 28) is set.

5. Applies for all faults except TXMASK event occurred
6. Except for TXMASK event occurred and Overtemperature Protection
7. If overvoltage is reached, but none of the low_vds comparator(s) triggers, VOUT1/2 is still regulated below VVOUTMAX.
8. In indicator or low current PWM mode (`mode_setting` (see page 26)=01) the register `fault_ovp` is not set under an overvoltage conditions. The output voltage is nevertheless kept below VVOUTMAX.
9. In constant voltage mode (5V generation, register bit `const_v_mode=1`) this fault is disabled.
10. To avoid errors in short LED detection for LEDs with a high leakage current
11. The LED short circuit protection is disabled in indicator mode (or low current mode using PWM) (`mode_setting` on page 26=01b)
12. In constant voltage mode (`const_v_mode=1`) the DCDC will not be automatically re-enabled.



8.4.5 Flash Timeout

If the flash is started a timeout timer is started in parallel. If the flash duration defined by the STROBE input ($strobe_on=1$ and $strobe_type=1$, see [Figure 25 on page 18](#)) exceeds $tFLASHTIMEOUT$ (adjustable by register $flash_timeout$ (see [page 26](#))), the DCDC is stopped and the flash current sources (on pin LED_OUT1/2) are disabled (ramping down) and $fault_timeout$ is set.

If the flash duration is defined by the timeout timer itself ($strobe_on = 0$, see [Figure 23 on page 17](#)), the register $fault_timeout$ is set after the flash has been finished.

8.4.6 Supply Undervoltage Protection

If the voltage on the pin VIN (=battery voltage) is or falls below $VUVLO$, the AS3649 is kept in shutdown state and all registers are set to their default state.

8.4.7 NTC - Flash LED Overtemperature Protection

The ntc_on (see [page 25](#))=1, the flash LED is protected by the AS3649 using an internal comparator connected to NTC and an current source controlled by $ntc_current$ (see [page 25](#)) (V_{NTC_TH} , I_{NTC} as shown in [Figure 16, "Internal Circuit Diagram," on page 11](#)); once it is triggered, the DCDC is stopped, the current sources are disabled (instantaneous) and the bit $fault_ntc$ (see [page 28](#)) is set.

As the external NTC cannot measure the LED temperature in real time during a high current flash pulse (the duration from heating up of the LED until the NTC recognizes a too hot LED is usually too long), it is advisable to measure the LED temperature before the flash pulse (with the [ADC](#) (see [page 19](#)) and $ntc_current$ (see [page 25](#))) and judge how much current can be driven through the LED (to be estimated depending on LED heat sink and is usually specified by the LED manufacturer).

8.5 Operating Mode and Currents

The output currents and operating mode currents are selected according to the following table:

Table 5. Operating Mode and Current Settings

AS3649 Configuration				Operating Mode and Currents		
ON, SCL, SDA	TXMASK/TORCH	STROBE	mode setting (see page 26)	Condition	Mode	LED_OUT1/2 Output current
ON=0	X	X	X	X	Shutdown All registers are reset to their default values	0
ON=1; I ² C commands are accepted on pins SCL and SDA	X	X	00	$txmask_torch_mode$ (see page 23) not 10	standby	0
	0	X		$txmask_torch_mode = 10$		
	1	X		$txmask_torch_mode = 10$	external torch mode	LED current is defined by the 6LSB ¹ bits of $led_current1$ and $led_current2$
	X	X	01		indicator mode or low current pwm mode ²	LED current is defined by the 6LSB bits (bits 5...0) of $led_current1$ and $led_current2$ pwm modulated defined by register $inct_pwm$ (31.5kHz: 1/16...4/16) or 7.9kHz: 1/64...3/64)
	X	X	10		torch light mode	LED current is defined by the 6LSB ² bits (5...0) of $led_current1$ and $led_current2$
	X	X	11	$strobe_on$ (see page 28) = 0	flash mode;	LED current is defined by $led_current1$ and $led_current2$ - the current can be reduced during flash, see Flash Current Reductions below
	X	0->1		$strobe_on = 1$ and $strobe_type$ (see page 28) = 0	flash duration defined by $flash_timeout$ (see page 26)	
X	1	$strobe_on = 1$ and $strobe_type = 1$		flash duration defined by STROBE input; timeout defined by $flash_timeout$		



1. The MSB bit of this register not used to protect the LED; therefore the maximum torch light current = $1/4 \times$ the maximum flash current
2. The low current mode is a general purpose PWM mode to drive less current through the LED in average, but keep the actual pulsed current in a range where the light output from the LED is still specified. As only the 6 LSBs of `led_current1` and `led_current2` is used the maximum current is limited to $1/4$ of the maximum flash current.

Always keep `led_current1` \geq `led_current2`.

8.5.1 Flash Current Reductions

TXMASK.

Usually the flash current is defined by the register `led_current1` and `led_current2`. If the TXMASK/TORCH input is used and (configured by `txmask_torch_mode=01`), the flash current is reduced to `flash_txmask_current` if TXMASK/TORCH=1.

Current Reduction by VIN Measurements in Flash Mode and Diagnostic Pulse.

Due to the high load of the flash driver and the ESR of the battery (especially critical at low temperatures), the voltage on the battery drops. If the voltage drops below the reset threshold, the system would reset. To prevent this condition the AS3649 monitors the battery voltage and keeps it above `vin_low_v` as follows:

If the voltage on VIN before the flash is below `vin_low_v`, the DCDC is not started at all. Otherwise during flash, if the voltage on VIN drops below the threshold defined by `vin_low_v`, the flash current is reduced (or ramping of the current is stopped during flash current startup) and `status_uvlo` is set. The timing for the reduction of the current is $2\mu\text{s}/\text{LSB}$ current change.

During the flash pulse the actual used current can be readout by the register `led_current_actual`.

After the flash pulse the minimum current can be readout by the register `led_current_min` - this allows to adjust the camera sensitivity (gain or iso-settings) for the subsequent flash pulse (e.g. when using a pre-flash and a main flash pulse).

The internal circuit for low voltage current reductions are shown in [Figure 19](#):

Figure 19. Low Voltage Current Reduction Internal Circuit

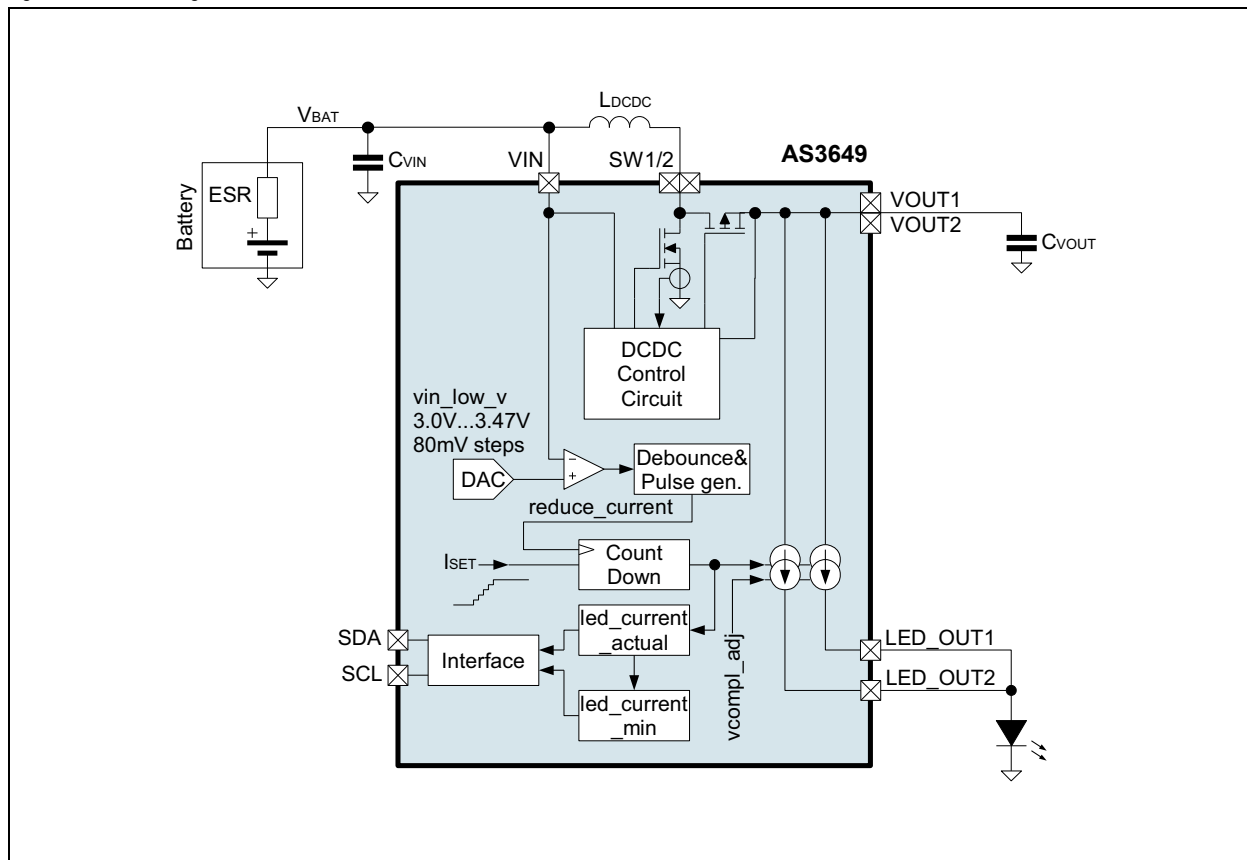



A mobile phone camera flash system can trigger a diagnostic flash and a main-flash:

The diagnostic flash is initiated by the processor. After this diagnostic flash, the determined maximum flash current can be read back through the I²C interface from register `led_current_min` (see page 30) and used for the setting for the main flash. Therefore the current in the main-flash is constant and additionally the camera system can use this current for picture quality adjustments - the waveforms for this concept are shown in Figure 20:

Figure 20. Low Voltage Current Reduction Waveform with Diagnostic-Flash and Main-Flash Phase

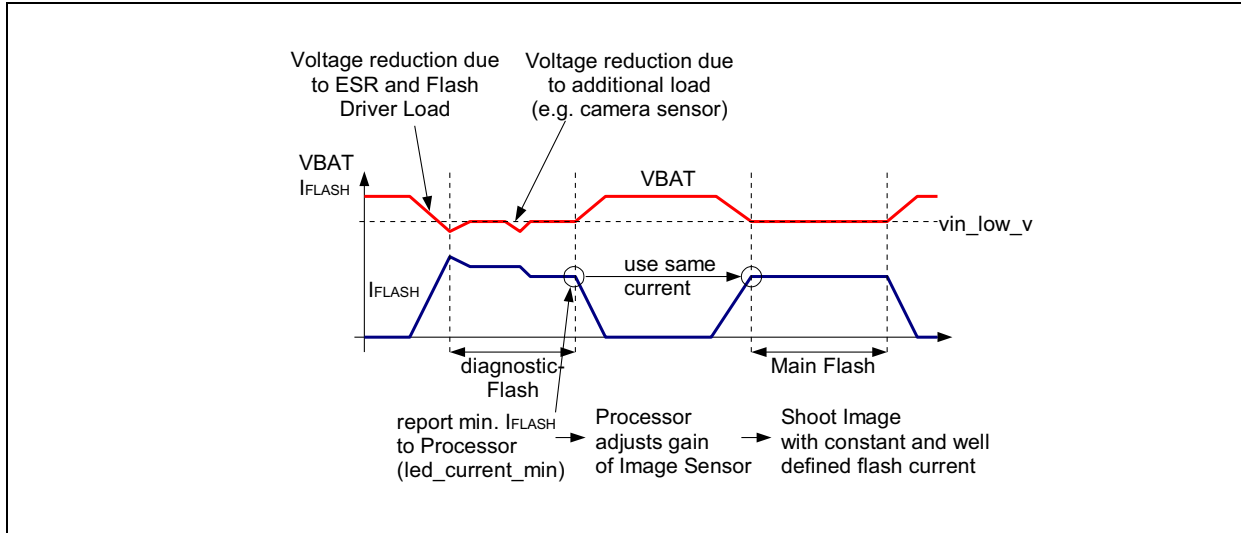

Short Diagnostic Pulse.

If the diagnostic flash should be short (e.g. 4ms) it is recommended to operate this diagnostic flash at a different `vcompl_adj` (see page 27) and higher `vin_low_v` (see page 24) settings compared to the main flash as shown in Figure 21:

Figure 21. Low Voltage Current Reduction Waveform with Short Diagnostic-Flash and Main-Flash Phase

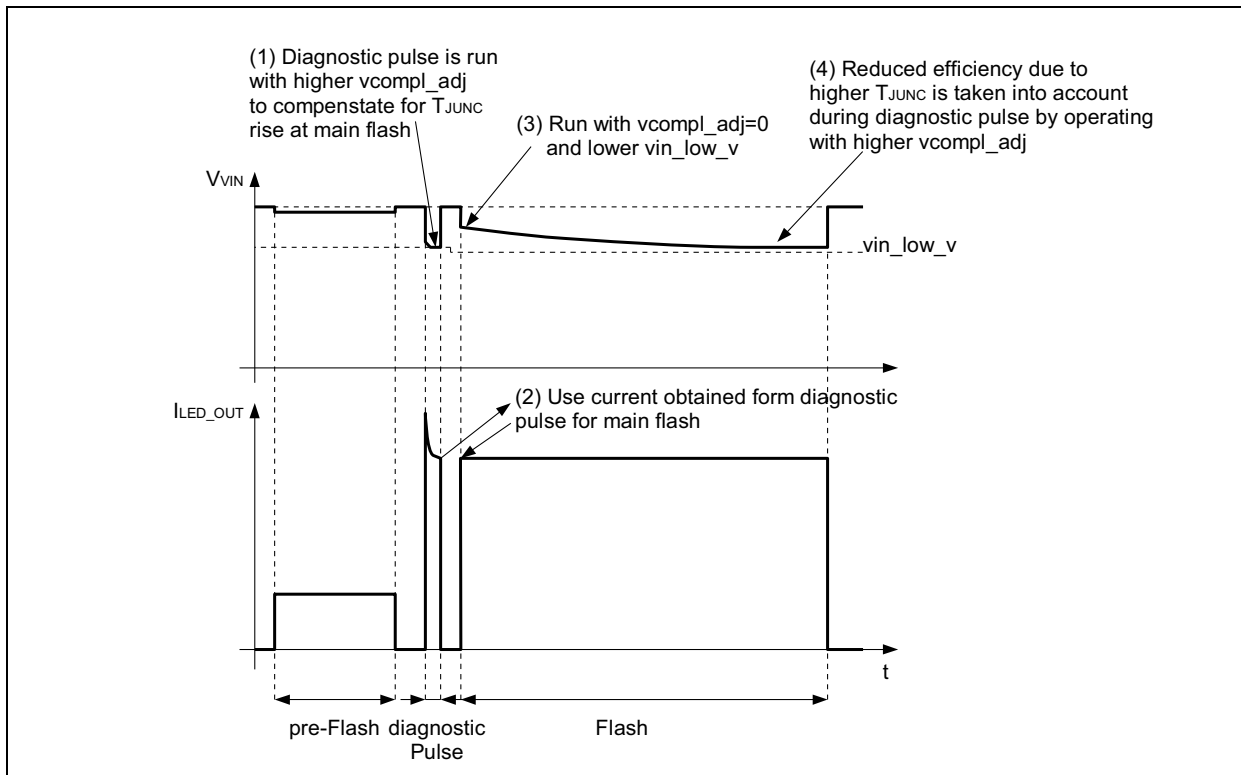



The AS3649 efficiency reduction during main flash can be compensated during a short diagnostic flash by adjusting `vcompl_adj` as shown in Figure 21. Reducing `vin_low_v` during main flash additionally takes into account a longer time constant of the battery for high loads and allows a very short diagnostic pulse (only 4ms).

Using the ams AG linux software driver it is possible to calculate the maximum flash duration for a given operating condition (additionally using `T_JUNCTION` measured through the AS3649 ADC).

8.5.2 Load Balancing

To improve the efficiency of the AS3649 for LEDs with unmatched forward voltage and reduce the internal power dissipation of the AS3649, set the bit `load_balance_on=1`. This bit can change the currents through the LEDs by up to $\pm 15\%$ to match the forward voltage of the LED better as shown in Figure 22:

Figure 22. Load Balancing

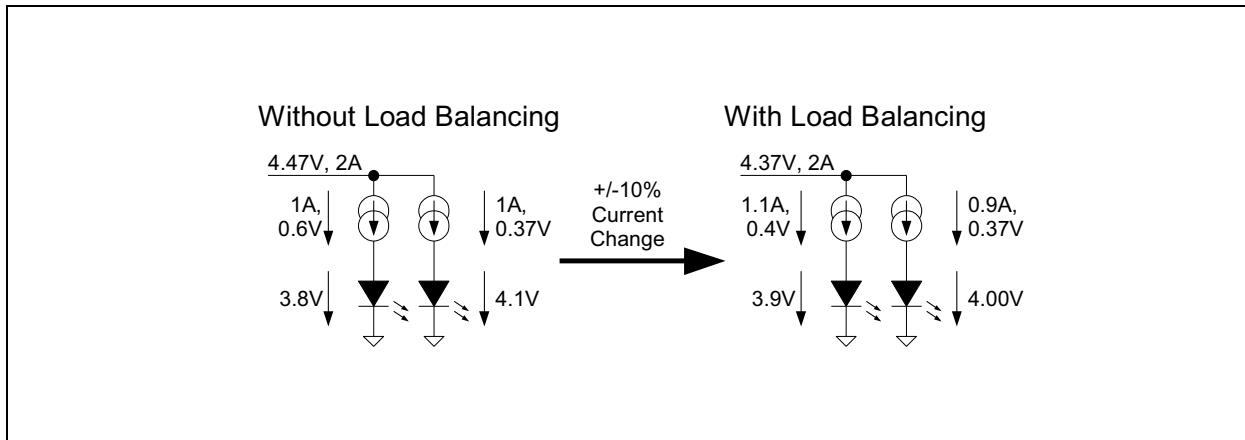

8.6 Flash Strobe Timings

The flash timing are defined as follows:

- Flash duration defined by register `flash_timeout` and flash is started immediately when this mode is selected by the I^2C command (see Figure 23):
set `strobe_on = 0`, start the flash by setting `mode_setting = 11b`
- Flash duration defined by register `flash_timeout` and flash started with a rising edge on pin STROBE (see Figure 24):
set `strobe_on = 1` and `strobe_type = 0`
- Flash start and timing defined by the pin STROBE; the flash duration is limited by the timeout timer defined by `flash_timeout` (see Figure 25 and Figure 26):
set `strobe_on = 1` and `strobe_type = 1`

Figure 23. AS3649 Flash Duration Defined by `flash_timeout` Without Using STROBE Input

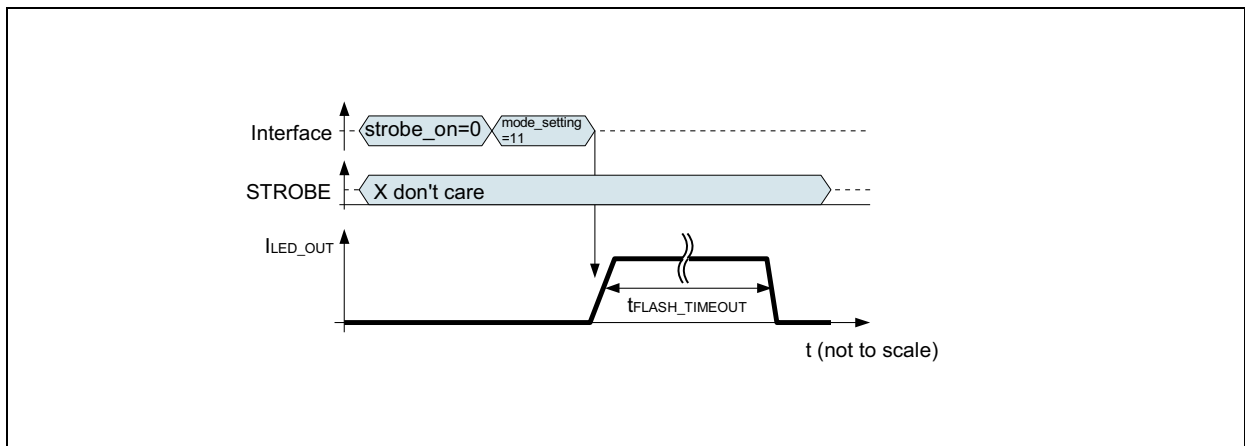



Figure 24. AS3649 Flash Duration Defined by *flash_timeout*, Starting Flash with STROBE Rising Edge

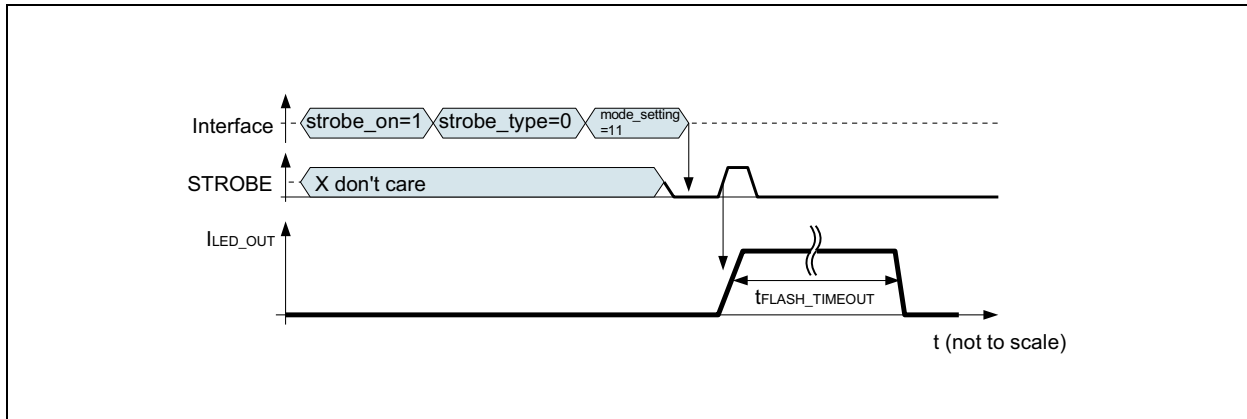

Figure 25. AS3649 Flash Duration and Start Defined by STROBE, Limited by *flash_timeout*; Timer Not Expired

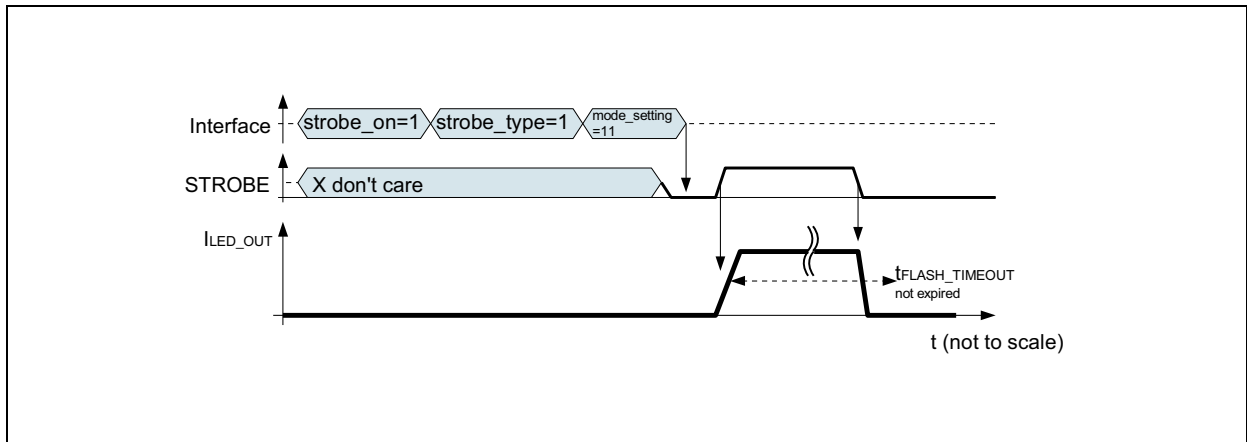
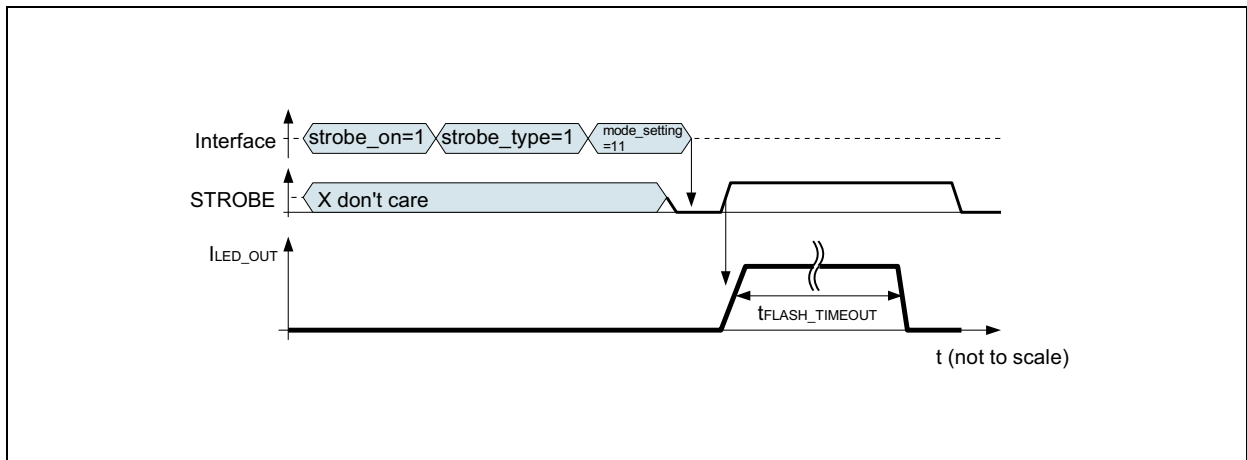

Figure 26. AS3649 Flash Duration and Start Defined by STROBE, Limited by *flash_timeout*; Timer Expired





8.7 ADC

The internal ADC is used to monitor LED temperature and DIE temperature. To operate the ADC, set the `adc_channel` (see page 27) and start the conversion by `adc_convert`. When `adc_convert` returns to '0' the result is available in register `adc_result` (see page 30) (Bits 9...7) and `adc_result_lsbs` (Bits 1...0).

The DIE junction temperature measurement returns the value according to Table 6:

Table 6. Junction Temperature Measurement ADC result

Junction Temperature - °C	ADC Return Value (10bit)
-30	352
-20	343
-10	334
0	325
10	316
20	306
30	297
40	287
50	278
60	268
70	259
80	249
90	239
100	229
110	219
120	209
130	199
140	189
150	179

8.8 I²C Serial Data Bus

The AS3649 supports the I²C bus protocol. A device that sends data onto the bus is defined as a transmitter and a device receiving data as a receiver. The device that controls the message is called a master. The devices that are controlled by the master are referred to as slaves. A master device that generates the serial clock (SCL), controls the bus access, and generates the START and STOP conditions must control the bus. The AS3649 operates as a slave on the I²C bus. Within the bus specifications a standard mode (100kHz maximum clock rate) and a fast mode (400kHz maximum clock rate) are defined. The AS3649 works in both modes. Connections to the bus are made through the open-drain I/O lines SDA and SCL.

The following bus protocol has been defined (Figure 27):

- Data transfer may be initiated only when the bus is not busy.
- During data transfer, the data line must remain stable whenever the clock line is HIGH. Changes in the data line while the clock line is HIGH are interpreted as control signals.

Accordingly, the following bus conditions have been defined:

Bus Not Busy. Both data and clock lines remain HIGH.

Start Data Transfer. A change in the state of the data line, from HIGH to LOW, while the clock is HIGH, defines a START condition.

Stop Data Transfer. A change in the state of the data line, from LOW to HIGH, while the clock line is HIGH, defines the STOP condition.



Data Valid. The state of the data line represents valid data when, after a START condition, the data line is stable for the duration of the HIGH period of the clock signal. The data on the line must be changed during the LOW period of the clock signal. There is one clock pulse per bit of data.

Each data transfer is initiated with a START condition and terminated with a STOP condition. The number of data bytes transferred between START and STOP conditions are not limited, and are determined by the master device. The information is transferred byte-wise and each receiver acknowledges with a ninth bit.

Acknowledge. Each receiving device, when addressed, is obliged to generate an acknowledge after the reception of each byte. The master device must generate an extra clock pulse that is associated with this acknowledge bit.

A device that acknowledges must pull down the SDA line during the acknowledge clock pulse in such a way that the SDA line is stable LOW during the HIGH period of the acknowledge-related clock pulse. Of course, setup and hold times must be taken into account. A master must signal an end of data to the slave by not generating an acknowledge bit on the last byte that has been clocked out of the slave. In this case, the slave must leave the data line HIGH to enable the master to generate the STOP condition.

Figure 27. Data Transfer on I²C Serial Bus

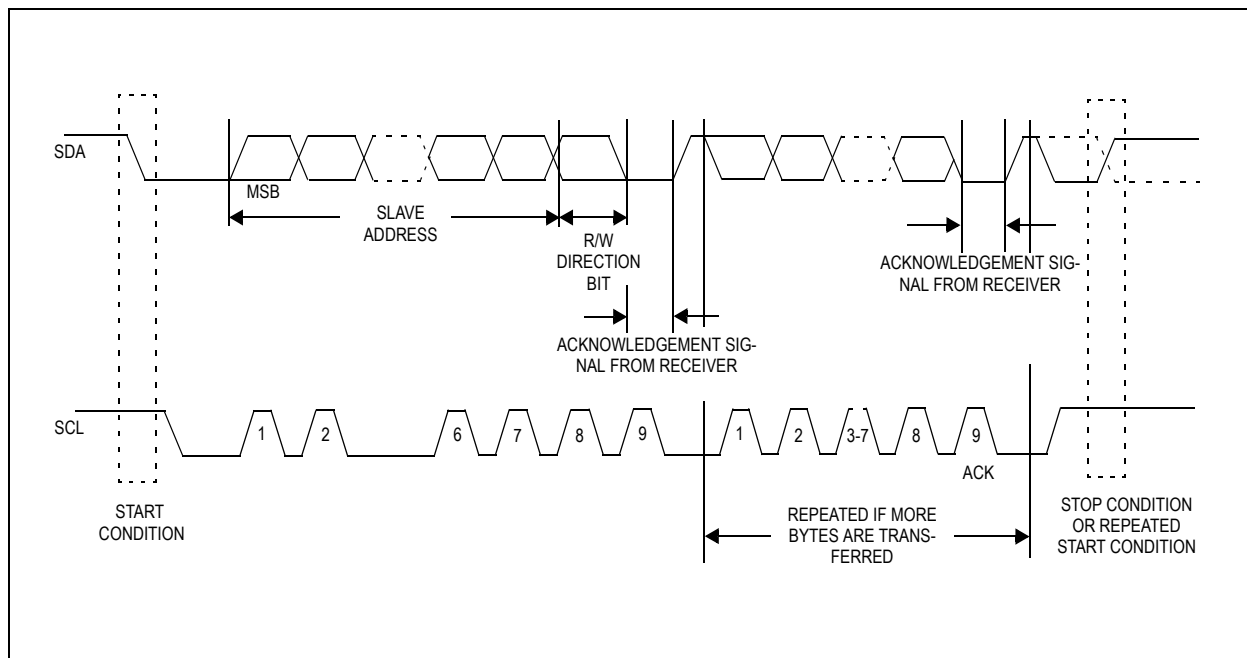

Depending upon the state of the R/W bit, two types of data transfer are possible:

1. **Data transfer from a master transmitter to a slave receiver.** The first byte transmitted by the master is the slave address. Next follows a number of data bytes. The slave returns an acknowledge bit after each received byte. Data is transferred with the most significant bit (MSB) first.
2. **Data transfer from a slave transmitter to a master receiver.** The master transmits the first byte (the slave address). The slave then returns an acknowledge bit, followed by the slave transmitting a number of data bytes. The master returns an acknowledge bit after all received bytes other than the last byte. At the end of the last received byte, a "not acknowledge" is returned. The master device generates all of the serial clock pulses and the START and STOP conditions. A transfer is ended with a STOP condition or with a repeated START condition. Since a repeated START condition is also the beginning of the next serial transfer, the bus is not released. Data is transferred with the most significant bit (MSB) first.

The AS3649 can operate in the following two modes:

1. **Slave Receiver Mode (Write Mode):** Serial data and clock are received through SDA and SCL. After each byte is received an acknowledge bit is transmitted. START and STOP conditions are recognized as the beginning and end of a serial transfer. Address recognition is performed by hardware after reception of the slave address and direction bit (see Figure 28). The slave address byte is the first byte received after the master generates the START condition. The slave address byte contains the 7-bit AS3649 address, which is 0110000, followed by the direction bit (R/W), which, for a write, is 0.¹³ After receiving and decoding the slave address byte the device outputs an acknowledge on the SDA line. After the AS3649 acknowledges the slave address + write bit, the master transmits a



register address to the AS3649. This sets the register pointer on the AS3649. The master may then transmit zero or more bytes of data, with the AS3649 acknowledging each byte received. The address pointer will increment after each data byte is transferred. The master generates a STOP condition to terminate the data write.

2. **Slave Transmitter Mode (Read Mode):** The first byte is received and handled as in the slave receiver mode. However, in this mode, the direction bit indicates that the transfer direction is reversed. Serial data is transmitted on SDA by the AS3649 while the serial clock is input on SCL. START and STOP conditions are recognized as the beginning and end of a serial transfer (Figure 29 and Figure 30). The slave address byte is the first byte received after the master generates a START condition. The slave address byte contains the 7-bit AS3649 address, which is 0110000, followed by the direction bit (R/W), which, for a read, is 1.¹⁴ After receiving and decoding the slave address byte the device outputs an acknowledge on the SDA line. The AS3649 then begins to transmit data starting with the register address pointed to by the register pointer. If the register pointer is not written to before the initiation of a read mode the first address that is read is the last one stored in the register pointer. The AS3649 must receive a “not acknowledge” to end a read.

Figure 28. Data Write - Slave Receiver Mode

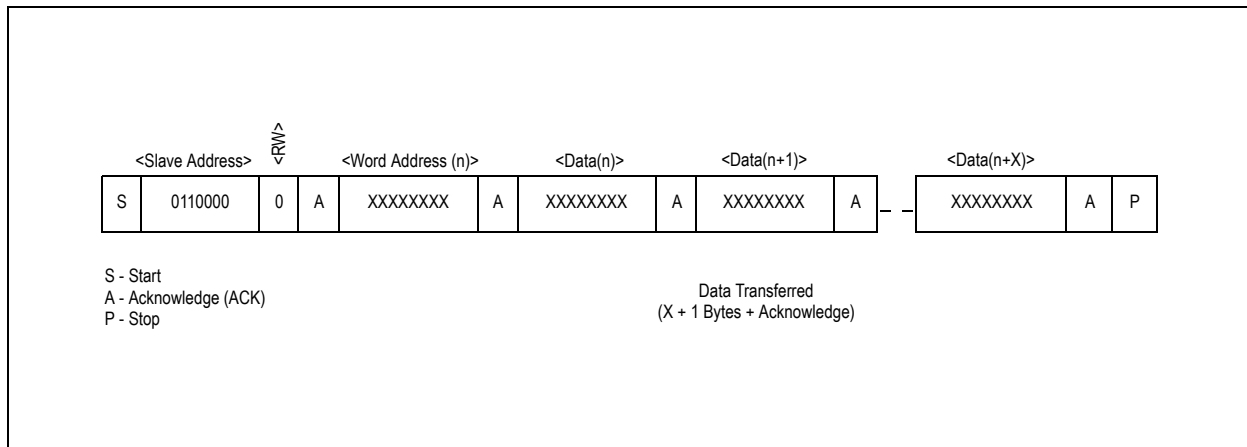
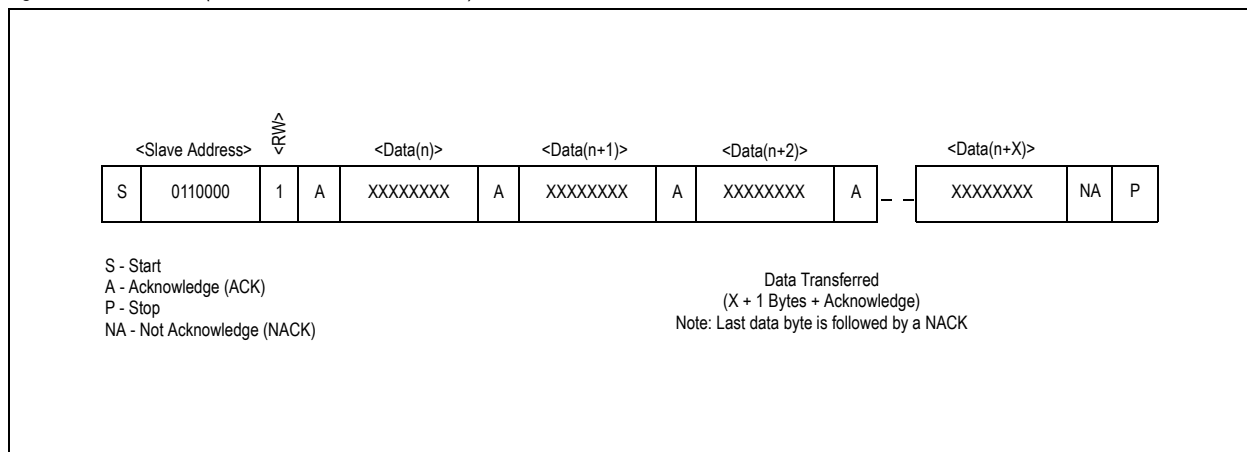

Figure 29. Data Read (from Current Pointer Location) - Slave Transmitter Mode



13. The address for writing to the AS3649 is 60h = 01100000b

14. The address for read mode from the AS3649 is 61h = 01100001b



Figure 30. Data Read (Write Pointer, Then Read) - Slave Receive and Transmit

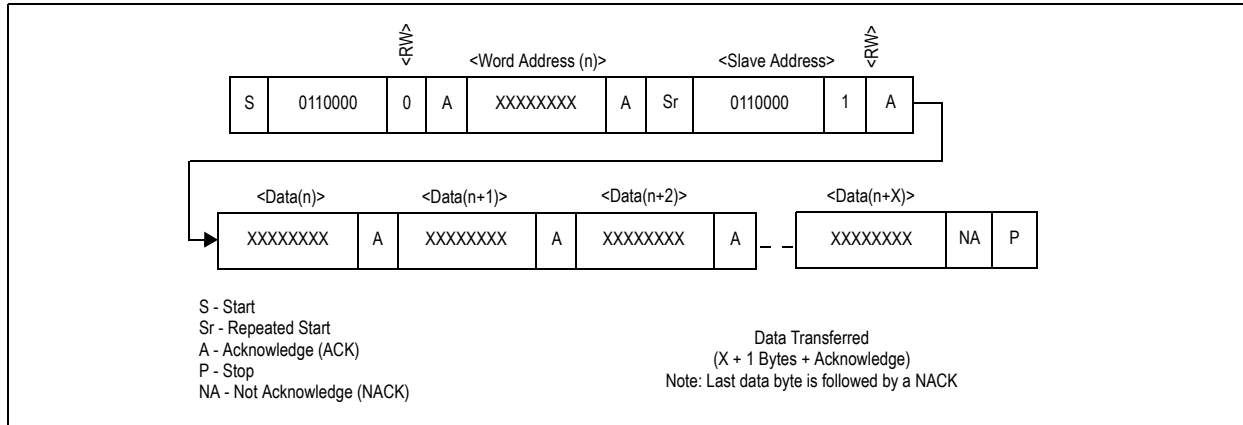

8.9 Register Description

Table 7. *ChipID Register*

Addr: 0		ChipID Register		
This register has a fixed ID				
Bit	Bit Name	Default	Access	Description
2:0	version	Xh	R	AS3649 chip version number
7:3	fixed_id	11000b	R	This is a fixed identification (e.g. to verify the I ² C communication)

Table 8. *Current Set LED1 Register*

Addr: 1		Current Set LED1 Register			
This register defines design versions					
Bit	Bit Name	Default	Access	Description	
7:0	led_current1	9Ch	R/W	Define the current on pin LED_OUT1; torch mode uses bits 5:0 of this current setting (max. 1/4 of full current setting) indicator or low current pwm mode uses only 5:0 of this current setting (max. 1/4 of full current setting) Note: Always keep <code>led_current1</code> >= <code>led_current2</code>	
				0h	0mA
				1h	7.8mA
				2h	11.7mA
			
				3Fh	250mA (maximum current for torch light mode, indicator or low current pwm mode, <code>mode_setting=01</code> or <code>10</code>)
			
				7Fh	500mA
			
				9Ch	613.3mA - default setting
			
				FEh	996mA (1245mA ¹ if <code>current_boost=1</code>)
FFh	1000mA (1250mA ¹ if <code>current_boost=1</code>)				

1. Only use `current_boost=1` for currents > 1000mA (code >= CCh)



Table 9. Current Set LED2 Register

Addr: 2		Current Set LED2 Register			
		This register defines design versions			
Bit	Bit Name	Default	Access	Description	
7:0	led_current2	9Ch	R/W	Define the current on pin LED_OUT2; torch mode uses bits 5:0 of this current setting (max. 1/4 of full current setting) indicator or low current pwm mode uses only 5:0 of this current setting (max. 1/4 of full current setting) Note: Always keep <code>led_current1</code> >= <code>led_current2</code>	
				0h	0mA
				1h	7.8mA
				2h	11.7mA
			
				3Fh	250mA (maximum current for torch light mode, indicator or low current pwm mode, <code>mode_setting=01</code> or <code>10</code>)
			
				7Fh	500mA
			
				9Ch	613.3mA - default setting
			
				FEh	996mA (1245mA ¹ if <code>current_boost=1</code>)
				FFh	1000mA (1250mA ¹ if <code>current_boost=1</code>)

1. Only use `current_boost=1` for currents > 1000mA (code >= CCh)

Table 10. TXMask Register

Addr: 3		TXMask Register			
		This register defines the TXMask settings and coil peak current			
Bit	Bit Name	Default	Access	Description	
1:0	txmask_torch_mode	00	R/W	Defines operating mode for input pin TXMASK/TORCH	
				00	pin has no effect
				01	txmask-mode; during flash if TXMASK/TORCH=1, the LED current is set to <code>flash_txmask_current</code> - (see TXMASK on page 15)
				10	external torch mode: if TXMASK/TORCH=1 and <code>mode_setting=00</code> , the AS3649 is set into external torch mode (LED current is defined by the 6LSB ¹ bits of <code>led_current1</code> and <code>led_current2</code>)
				11	don't use
3:2	coil_peak	10	R/W	Defines the maximum coil current (parameter ILIMIT)	
				00	ILIMIT = 2.5A
				01	ILIMIT = 2.9A
				10	ILIMIT = 3.3A
				11	ILIMIT = 3.7A



Table 10. TXMask Register (Continued)

Addr: 3		TXMask Register			
This register defines the TXMask settings and coil peak current					
Bit	Bit Name	Default	Access	Description	
7:4	flash_txmask_current ²	6h	R/W	Define the current on pin LED_OUT1 and LED_OUT2 (each current source) in flash mode if <code>txmask_torch_mode=01</code> and <code>TXMASK/TORCH=1</code>	
				0h	0mA
				1h	31mA (39mA if <code>current_boost=1</code>)
				2h	63mA (78mA if <code>current_boost=1</code>)
				3h	94mA (118mA if <code>current_boost=1</code>)
				4h	125mA (157mA if <code>current_boost=1</code>)
				5h	157mA (196mA if <code>current_boost=1</code>)
				6h	188mA (235mA if <code>current_boost=1</code>) - default
				7h	220mA (275mA if <code>current_boost=1</code>)
				8h	251mA (314mA if <code>current_boost=1</code>)
				9h	282mA (353mA if <code>current_boost=1</code>)
				Ah	314mA (392mA if <code>current_boost=1</code>)
				Bh	345mA (431mA if <code>current_boost=1</code>)
				Ch	376mA (471mA if <code>current_boost=1</code>)
				Dh	408mA (510mA if <code>current_boost=1</code>)
				Eh	439mA (549mA if <code>current_boost=1</code>)
Fh	471mA (588mA if <code>current_boost=1</code>)				

1. The MSB bit of this register not used to protect the LED; therefore the maximum current = 1/4 the maximum flash current
2. If `current_boost=1`, the LED current is increased by 25%.

Table 11. Low Voltage / NTC Register

Addr: 4		Low Voltage / NTC Register			
This register defines the operating mode with low battery voltages					
Bit	Bit Name	Default	Access	Description	
2:0	vin_low_v	4h	R/W	Voltage level on VIN where current reduction triggers during operation (see Current Reduction by VIN Measurements in Flash Mode and Diagnostic Pulse on page 15) - only in flash mode; if VIN drops below this voltage during current ramp up, the current ramp up is stopped; during operation the current is decreased until the voltage on VIN rises above this threshold - <code>status_uvlo</code> is set	
				0h	function is disabled
				1h	3.0V
				2h	3.07V
				3h	3.14V
				4h	3.22V - default
				5h	3.3V
				6h	3.38V
7h	3.47V				



Table 11. Low Voltage / NTC Register (Continued)

Addr: 4		Low Voltage / NTC Register			
This register defines the operating mode with low battery voltages					
Bit	Bit Name	Default	Access	Description	
3	ntc_on	0	R/W	Enable overtemperature protection on pin NTC (internal comparator comparing NTC to V _{NTC_TH})	
				0	disabled
				1	enabled
7:4	ntc_current	8h	R/W	Current through the NTC (I _{NTC}); it is enabled once the LED current source (LED_OUT1/2) is operating and ntc_on=1 or the ADC measures the LED temperature (see NTC - Flash LED Overtemperature Protection on page 14)	
				0h	off; can be used to use an external current to bias the NTC
				1h	40μA
				2h	80μA
				3h	120μA
				4h	160μA
				5h	200μA
				6h	240μA
				7h	280μA
				8h	320μA - default
				9h	360μA
				Ah	400μA
				Bh	440μA
				Ch	480μA
				Dh	520μA
Eh	560μA				
Fh	600μA				



Table 12. Flash Timer Register

Addr: 5		Flash Timer Register				
This register identifies the flash timer and timeout settings						
Bit	Bit Name	Default	Access	Description		
5:0	flash_timeout ¹	26h	R/W	Define the duration of the flash timer and timeout timer		
				00h ... 4ms	16h ... 92ms	2Bh ... 484ms
				01h ... 8ms	17h ... 96ms	2Ch ... 516ms
				02h ... 12ms	18h ... 100ms	2Dh ... 548ms
				03h ... 16ms	19h ... 104ms	2Eh ... 580ms
				04h ... 20ms	1Ah ... 108ms	2Fh ... 612ms
				05h ... 24ms	1Bh ... 112ms	30h ... 644ms
				06h ... 28ms	1Ch ... 116ms	31h ... 676ms
				07h ... 32ms	1Dh ... 120ms	32h ... 708ms
				08h ... 36ms	1Eh ... 124ms	33h ... 740ms
				09h ... 40ms	1Fh ... 128ms	34h ... 772ms
				0Ah ... 44ms	20h ... 132ms	35h ... 804ms
				0Bh ... 48ms	21h ... 164ms	36h ... 836ms
				0Ch ... 52ms	22h ... 196ms	37h ... 868ms
				0Dh ... 56ms	23h ... 228ms	38h ... 900ms
				0Eh ... 60ms	24h ... 260ms	39h ... 932ms
				0Fh ... 64ms	25h ... 292ms	3Ah ... 964ms
10h ... 68ms	26h ... 324ms	3Bh ... 996ms				
11h ... 72ms	27h ... 356ms	3Ch ... 1028ms				
12h ... 76ms	28h ... 388ms	3Dh ... 1060ms				
13h ... 80ms	29h ... 420ms	3Eh ... 1092ms				
14h ... 84ms	2Ah ... 452ms	3Fh ... 1124ms				
				15h ... 88ms		

1. Internal calculation for codes above 20h: flash timeout [ms] = (flash_timeout-32) * 32 + 132 [ms]

Table 13. Control Register

Addr: 6		Control Register			
This register identifies the operating mode and includes an all on/off bit					
Bit	Bit Name	Default	Access	Description	
1:0	mode_setting	00	R/W	Define the AS3649 operating mode - see Table 5, "Operating Mode and Current Settings," on page 14	
				00	standby/shutdown or external torch mode if txmask_torch_mode (page 23)=10
				01	indicator mode (or low current mode using PWM) LED current is defined by the 6LSB ¹ bits of led_current1 and led_current2 pwm modulated defined by register inct_pwm (31.5kHz: 1/16...4/16, 7.9kHz: 1/64...3/64)
				10	torch light mode: LED current is defined by the 6LSB ² bits of led_current1 and led_current2
				11	flash mode: LED current is defined by led_current1 and led_current2 (mode_setting is automatically cleared after a flash pulse)



Table 13. Control Register (Continued)

Addr: 6		Control Register			
This register identifies the operating mode and includes an all on/off bit					
Bit	Bit Name	Default	Access	Description	
3:2	min_on_increase	00	R/W	Increase min. on time of DCDC converter - use for diagnostic pulse, if freq_switch_on=1 . If this register is not 00 and freq_switch_on=1 , the DCDC converter will use 4MHz operation forced PWM mode or pass-through mode but will not switch to 1MHz operation	
				00	100% - default min. on time
				01	108%
				10	131%
				11	157%
4	force_dcdc_on	0	R/W	Force DCDC operation even in pass-through mode - use for diagnostic pulse, if freq_switch_on=1	
				0	DCDC is only enabled when needed; default
7:5	vcompl_adj	000b	R/W	Increase voltage compliance of current source for diagnostic pulses - see Short Diagnostic Pulse on page 16	
				000	default - 0mV
				001	14mV (26mV if current_boost=1)
				010	29mV (51mV if current_boost=1)
				011	43mV (77mV if current_boost=1)
				100	57mV (103mV if current_boost=1)
				101	71mV (129mV if current_boost=1)
				110	85mV (154mV if current_boost=1)
111	100mV (180mV if current_boost=1)				

1. The two MSB bits of this register are not used to protect the LED; therefore the maximum indicator (or low current mode using PWM) light current = 1/4 the maximum flash current multiplied by the duty cycle defined by [inct_pwm](#)
2. The two MSB bits of this register not used to protect the LED; therefore the maximum torch light current = 1/4 the maximum flash current

Table 14. Strobe Signalling / ADC Register

Addr: 7		Strobe Signalling / ADC Register			
This register defines the flash current reducing and mode for STROBE					
Bit	Bit Name	Default	Access	Description	
3:0	adc_channel	000b	R/W	Select ADC channel for conversion	
				000	NTC
				001	TJUNC
				010	VIN



Table 14. Strobe Signalling / ADC Register (Continued)

Addr: 7		Strobe Signalling / ADC Register			
This register defines the flash current reducing and mode for STROBE					
Bit	Bit Name	Default	Access	Description	
4	adc_convert	0	R/W	Start ADC conversion	
				0	ADC conversion finished
				1	Start ADC conversion - once finished the register bit is automatically reset and the result is stored in <code>adc_result</code>
5	dcdc_skip_enable	1	R/W	Allow pulseskip operation of DCDC - see Table 4 on page 12	
				0	Disabled - force 4MHz (1MHz) operation
				1	Enabled - can use pulseskip ¹
6	strobe_type	1	R/W	Defines if the STROBE input is edge or level sensitive; see also bit strobe_on (page 28)	
				0	STROBE input is edge sensitive
				1	STROBE input is level sensitive
7	strobe_on	1	R/W	Enables the STROBE input	
				0	STROBE input disabled
				1	STROBE input enabled in flash mode

1. Exception depending on [freq_switch_on \(see page 29\)](#) - see [Table 4 on page 12](#)

Table 15. Fault Register

Addr: 8		Fault Register			
This register identifies all the different fault conditions and provide information about the LED detection					
Bit	Bit Name	Default	Access	Description	
0	status_uvlo	0	R/sC ¹	an undervoltage event has happened - see Current Reduction by VIN Measurements in Flash Mode and Diagnostic Pulse on page 15	
				0	No
				1	Yes
1	reserved	0	R	reserved - don't use	
2	fault_ntc	0	R/sC ¹	LED overtemperature detection hit - see NTC - Flash LED Overtemperature Protection on page 14	
				0	No
				1	Yes
3	fault_txmask	0	R/sC ¹	TXMASK/TORCH event triggered during flash - see TXMASK event occurred on page 13	
				0	No
				1	Yes
4	fault_timeout	0	R/sC ¹	see Flash Timeout on page 14	
				0	No fault
				1	Flash timeout exceeded

Table 15. *Fault Register (Continued)*

Addr: 8		Fault Register			
This register identifies all the different fault conditions and provide information about the LED detection					
Bit	Bit Name	Default	Access	Description	
5	fault_overtemp	0	R/sC ¹	see Overtemperature Protection on page 13	
				0	No fault
				1	Junction temperature limit has been exceeded
6	fault_led_short	0	R/sC ¹	see Short Circuit Protection on page 13	
				0	No fault
				1	A shorted LED is detected (pin LED_OUT1/2)
7	fault_ovp	0	R/sC ¹	see Overvoltage Protection on page 13	
				0	No fault
				1	An overvoltage condition is detected (pin VOUT)

1. R/sC = Read, self clear; after readout the register is automatically cleared

Table 16. *PWM and Indicator Register*

Addr: 9		PWM and Indicator Register			
This register defines the PWM mode (e.g. for indicator) and 4/1MHz mode switching					
Bit	Bit Name	Default	Access	Description	
2:0	inct_pwm ¹	00	R/W	Define the AS3649 PWM with 31.5kHz or 7.9kHz operation for indicator or low current mode (mode_setting=01)	
				000	1/16 duty cycle / 31.5kHz
				001	2/16 duty cycle / 31.5kHz
				010	3/16 duty cycle / 31.5kHz
				011	4/16 duty cycle / 31.5kHz
				100	1/64 duty cycle / 7.9kHz; needs const_v_mode=1 (additional quiescent current)
				101	2/64 duty cycle / 7.9kHz; needs const_v_mode=1 (additional quiescent current)
				110	3/64 duty cycle / 7.9kHz; needs const_v_mode=1 (additional quiescent current)
				111	(4/64 duty cycle / 7.9kHz) - don't use; use 000 setting instead
3	freq_switch_on	0	R/W	Exact frequency switching between 4MHz/1MHz for operation close to maximum pulsewidth - see Table 4 on page 12	
				0	Pulseskip operation is allowed depending on dcdc_skip_enable (see page 28)
				1	if led_current1 >= 40h or led_current2 >= 40h and current_boost = 0, the DCDC is running at 4MHz or 1MHz and pulseskip is disabled - results in improved noise performance



Table 16. PWM and Indicator Register (Continued)

Addr: 9		PWM and Indicator Register			
This register defines the PWM mode (e.g. for indicator) and 4/1MHz mode switching					
Bit	Bit Name	Default	Access	Description	
4	load_balance_on	0	R/W	Balance the current sources (up to +/-15% of set current) to improve application efficiency for unmatched LED forward voltages - see Load Balancing on page 17	
				0	disabled
				1	enabled
5	const_v_mode	0	R/W	Enables Constant output voltage mode	
				0	Normal operation defined by mode_setting
				1	5V constant voltage mode on VOUT1/2; LED current can be controlled by registers mode_setting , led_current1 and led_current2 as in normal operating mode, but the ramping up/down of the current sources is disabled (instantaneous on/off of the LED current)

- Using 31.5kHz modulation avoids audible noise on the output capacitor CVOUT

Table 17. ADC Result Register

Addr: Ah		ADC Result Register		
This register reports the actual set LED current				
Bit	Bit Name	Default	Access	Description
7:0	adc_result	NA	R	Result of ADC conversion for channel adc_channel

Table 18. ADC Result LSBs Register

Addr: Bh		ADC Result LSBs Register		
This register reports the actual set LED current				
Bit	Bit Name	Default	Access	Description
1:0	adc_result_lsbs	NA	R	Result of ADC conversion for channel adc_channel

Table 19. Minimum LED Current Register

Addr: Eh		Minimum LED Current Register		
This register reports the minimum LED current from the last operation cycle				
Bit	Bit Name	Default	Access	Description
7:0	led_current_min ¹²³	00h	R	see Current Reduction by VIN Measurements in Flash Mode and Diagnostic Pulse (see page 15) and Figure 20 on page 16

- Only the current through LED_OUT1 is reported.
- As the internal change of this register is asynchronous to the readout, it is recommended to readout the register after the flash pulse. The register will store the minimum current through the LED after e.g. a previous flash. This current can be used for a subsequent flash pulse for a safe operating range.
- This register is only set if an actual current reduction happens ([status_uvlo](#) (see page 28)=1) otherwise [led_current_min](#)=0.



Table 20. Actual LED Current Register

Addr: Fh		Actual LED Current Register		
This register reports the actual set LED current				
Bit	Bit Name	Default	Access	Description
7:0	led_current_actual ¹²	00h	R	Actual set current through the current source (including all current reductions as described in Flash Current Reductions (see page 15) including LED current ramp up/down)

1. Only the current through LED_OUT1 is reported.
2. As the internal change of this register is asynchronous to the readout, it is recommended to readout the register twice and compare the results.

Table 21. Unlock Register Register

Addr: 80h		Unlock Register Register		
Protection for register Current Boost				
Bit	Bit Name	Default	Access	Description
7:0	unlock	NA	W	Write 55h into this register to enable access to register 81h

Table 22. Current Boost Register

Addr: 81h		Current Boost Register			
Increase output current by 25%					
Bit	Bit Name	Default	Access	Description	
0	current_boost ¹	0	R/W	Boost all LED currents by 25%	
				0	all LED current are as described in the tables
				1	all LED current are increased by 25%

1. Write 55h into register [unlock](#) (0x80) to enable access to this register (unlocking is only valid for the next I²C access) - required on any write access to this register



8.10 Register Map

Table 23. Register Map ¹

Register Definition	Addr	Default	Content							
			b7	b6	b5	b4	b3	b2	b1	b0
ChipID	0	Cxh	fixed_id				version			
Current Set LED1	1	9Ch	led_current1							
Current Set LED2	2	9Ch	led_current2							
TXMask	3	68h	flash_txmask_current				coil_peak		txmask_torch_mode	
Low Voltage / NTC	4	84h	ntc_current				ntc_on	vin_low_v		
Flash Timer	5	26h	flash_timeout							
Control	6	00h	vcompl_adj			force_dcdc_on	min_on_increase		mode_setting	
Strobe Signalling / ADC	7	E0h	strobe_on	strobe_type	dcdc_skip_enable	adc_convert	adc_channel			
Fault	8	00h	fault_ovp	fault_led_short	fault_overtemp	fault_timeout	fault_txmask	fault_ntc	reserved	status_uvlo
PWM and Indicator	9	00h			const_v_mode	load_balance_on	freq_switch_on	inct_pwm		
ADC Result	Ah	NA	adc_result							
ADC Result LSBs	Bh	NA	adc_result_lsbs							
Minimum LED Current	Eh	00h	led_current_min							
Actual LED Current	Fh	00h	led_current_actual							
Unlock Register	80h	00h	unlock							
Current Boost	81h	00h	current_boost							

1. Always write '0' to undefined register bits



9 Application Information

9.1 External Components

9.1.1 Input Capacitor C_{VIN}

Low ESR input capacitors reduce input switching noise and reduce the peak current drawn from the battery. Ceramic capacitors are required for input decoupling and should be located as close to the device as is practical.

Table 24. Recommended Input Capacitor

Part Number	C	TC Code	Rated Voltage	Size	Manufacturer
GRM188R60J106ME47	10 μ >3 μ F@4.5V >2 μ F@5.25V	X5R	6V3	0603	Murata www.murata.com
LMK107BBJ106MA	10 μ >3 μ F@4.5V	X5R	6V3	0603	Taiyo Yuden www.t-yuden.com

If a different input capacitor is chosen, ensure similar ESR value and at least 3 μ F capacitance at the maximum input supply voltage. Larger capacitor values (C) may be used without limitations.

Add a smaller capacitor in parallel to the input pin VIN (e.g. Murata GRM155R61C104, >50nF @ 3V, 0402 size).

9.1.2 Output Capacitor C_{VOUT}

Low ESR capacitors should be used to minimize VOUT ripple. Multi-layer ceramic capacitors are recommended since they have extremely low ESR and are available in small footprints. The capacitor should be located as close to the device as is practical.

X5R dielectric material is recommended due to their ability to maintain capacitance over wide voltage and temperature range.

Table 25. Recommended Output Capacitor

Part Number	C	TC Code	Rated Voltage	Size	Manufacturer
GRM219R61A106ME47	10 μ F +/-10% >4.2 μ F@5V	X5R	10V	0805 (2.0x1.25x0.85mm max 1mm height)	Murata www.murata.com
GRM21BR60J226M ¹	22 μ F >4.2 μ F@4.5V	X5R	6.3V	0805 (2.0x1.25x1.25mm max. 1.4mm height)	
GRM188R60J106ME84 ²	10 μ F +/-20% >4.2 μ F@4V	X5R	6.3V	0603 (1.6x0.8x0.85mm max. 0.95mm height)	

1. Use only for VLED < 4.1V
2. Use only for VLED < 3.75V

If a different output capacitor is chosen, ensure similar ESR values and at least 4.2 μ F capacitance at 5V output voltage.



9.1.3 Inductor LDCDC

The fast switching frequency (4MHz) of the AS3649 allows for the use of small SMDs for the external inductor. The saturation current $I_{SATURATION}$ should be chosen to be above the maximum value of I_{LIMIT} ¹⁵. The inductor should have very low DC resistance (DCR) to reduce the I^2R power losses - high DCR values will reduce efficiency.

Table 26. Recommended Inductor

Part Number	L	DCR	ISATURATION	Size	Manufacturer
LQM32PN1R0MG0	1.0μH >0.6μH @ 3.0A	60mΩ	3.0A ¹	3.2x2.5x0.9mm max 1.0mm height	Murata www.murata.com
SPM4012T-1R0M	1.0μH +/-20%	38mΩ	4.57A	4.4x4.1x1.2 mm height is max	TDK www.tdk.com
SPM3012T-1R0M	1.0μH +/-20%	57mΩ +/-10%	3.4A ²	3.2x3x1.2 mm height is max	
CIG32W1R0MNE	1.0μH >0.7μH @ 2.7A >0.6μH @ 3.0A	60mΩ +/-25%	3.0A ⁴	3.2x2.5mm max 1.0mm height	Samsung Electro-Mechanics www.sem.samsung.co.kr
CKP3225N1R0M	1.0μH >0.6μH @ 3.0A	<60mΩ	3.0A ⁴	3.2x2.5x0.9mm max 1.0mm height	Taiyo Yuden www.t-yuden.com
NRH2412T1R0N	1.0μH >0.6μH @ 2.5A	77mΩ	2.5A ³	2.4x2.4x1.2mm (height is max.)	
MAMK2520T1R0M	1.0μH >0.6μH @ 2.75A	45mΩ	3.1A ⁴	2.5x2.0x1.2mm height is max	

- Flash pattern: 200ms/3A, 200ms pause, 200ms/3A, 2s then repeat again (no limit on the number of total cycles)
Alternative pattern with 1000ms/1.6A, 200ms pause, 200ms/3A, 200ms pause, 200ms/3A, 2s then repeat again. (no limit on the number of total cycles). Use only up to `coil_peak=2.9A` setting
- Inductance changes by -30%, use only up to `coil_peak=3.3A` setting
- Use only for `coil_peak=2.5A` setting.
- Use only up to `coil_peak=2.9A` setting.

If a different inductor is chosen, ensure similar DCR values and at least 0.6μH inductance at I_{LIMIT} .

9.1.4 Thermistor (NTC)

The NTC is used to protect the LED against overheating (hardware protection inside the AS3649, which works without any software - see [NTC - Flash LED Overtemperature Protection on page 14](#)).

The thermistor has to be thermally coupled to the LED (and therefore as close as possible to the LED) and it shall not share the same ground connection as the LED return ground (if they share the same ground connection the high current through the LED will offset the measurement of the NTC).

Table 27. Recommended Thermistors

Part Number	Resistance @ 25°C	B-constant 25/50°C	Size	Manufacturer
NCP03WL224E05RL	220kΩ +/-3%	4485K +/-1%	0201	Murata www.murata.com
NCP03WL104E05RL	100kΩ +/-3%	4485K +/-1%		
NCP15WF104F03RC	100kΩ		0402	
NCP15WL683J03RC	68kΩ			

It is recommended to use 220kΩ resistance for a detection threshold of 125°C, 100kΩ for 110°C and 68kΩ for 80°C LED temperature detection threshold.

¹⁵. Can be adjusted in I^2C mode with register `coil_peak` (see page 23)



9.2 PCB Layout Guideline

The high speed operation requires proper layout for optimum performance. Route the power traces first and try to minimize the area and wire length of the two high frequency/high current loops:

Loop1: CVIN/CVIN2 - LDCDC - pin SW1/2 - pin GND - CVIN/CVIN2

Loop2: CVIN/CVIN2 - LDCDC - pin SW1/2 - pin VOUT1/2 - CVOUT - pin GND - CVIN/CVIN2

At the pin GND a single via (or more vias, which are closely combined) connects to the common ground plane. This via(s) will isolate the DCDC high frequency currents from the common ground (as most high frequency current will flow between Loop1 and Loop2 and will not pass the ground plane) - see the 'island' in [Figure 31](#).

Figure 31. Layout Recommendation

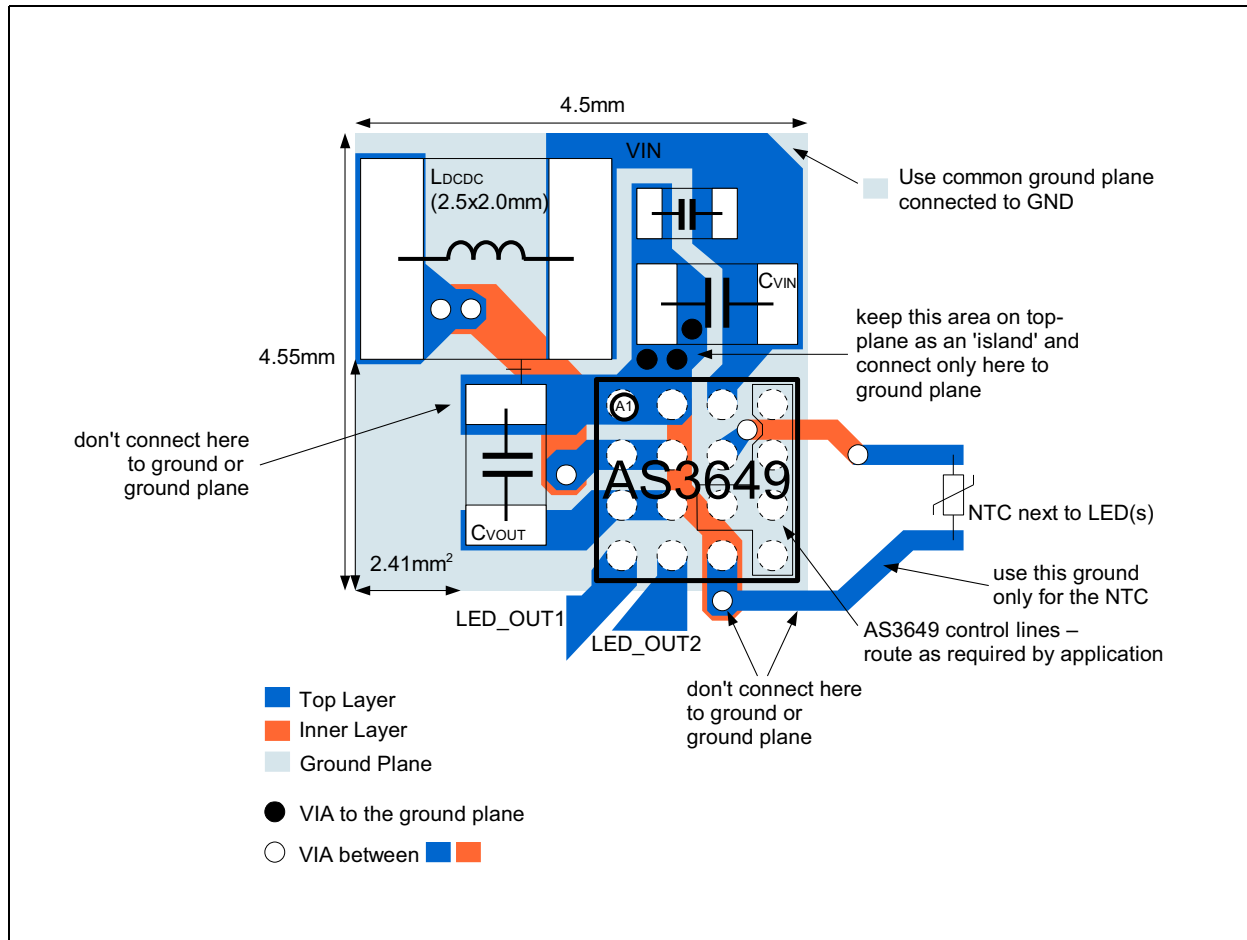

Note: If component placement rules allow, move all components close to the AS3649 to reduce the area and length of Loop1 and Loop2.

It is recommended to use the main ground plane for the LED ground connections (improved thermal performance of the LEDs) - it is recommended to use a separate ground line as shown [Figure 31](#) for the ground connection of the NTC (this avoids errors for the temperature measurement of the LEDs due to the high LED current in the main ground plane).

Keep the LED path (from pin LED_OUT1/2 to the LED and the ground return path) below 10cm (represents an inductance of less than 100nH).

An additional 100nF (e.g. Murata GRM155R61C104, >50nF @ 3V, 0402 size) capacitor CVIN2 in parallel to CVIN is recommended to filter high frequency noise for the power supply of AS3649. This capacitor should be as close as possible to the AGND/VIN pins of AS3649.



9.3 5V Operating Mode

The AS3649 can be used to power a 5V system (e.g. audio amplifier). The operating mode is selected by setting register bit [const_v_mode](#) (page 30)=1.

Note: There is always a diode between VIN and VOUT1/2 due to the internal circuit. Therefore VOUT1/2 cannot be completely switched off

Figure 32. 5V Operating Mode

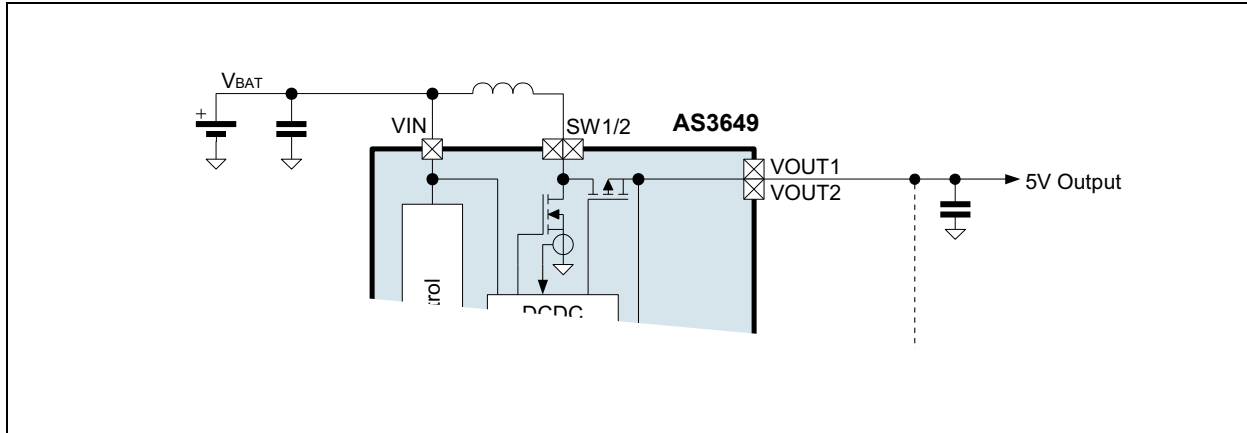



10 Package Drawings and Markings

Figure 33. WL-CSP16 Marking

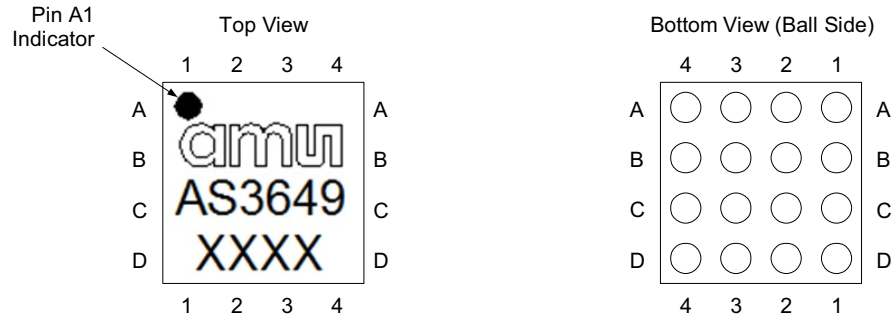

Note:

- Line 1: ams AG logo
- Line 2: AS3649
- Line 3: <Code>
Encoded Datecode (4 characters)

Figure 34. WL-CSP16 Package Dimensions

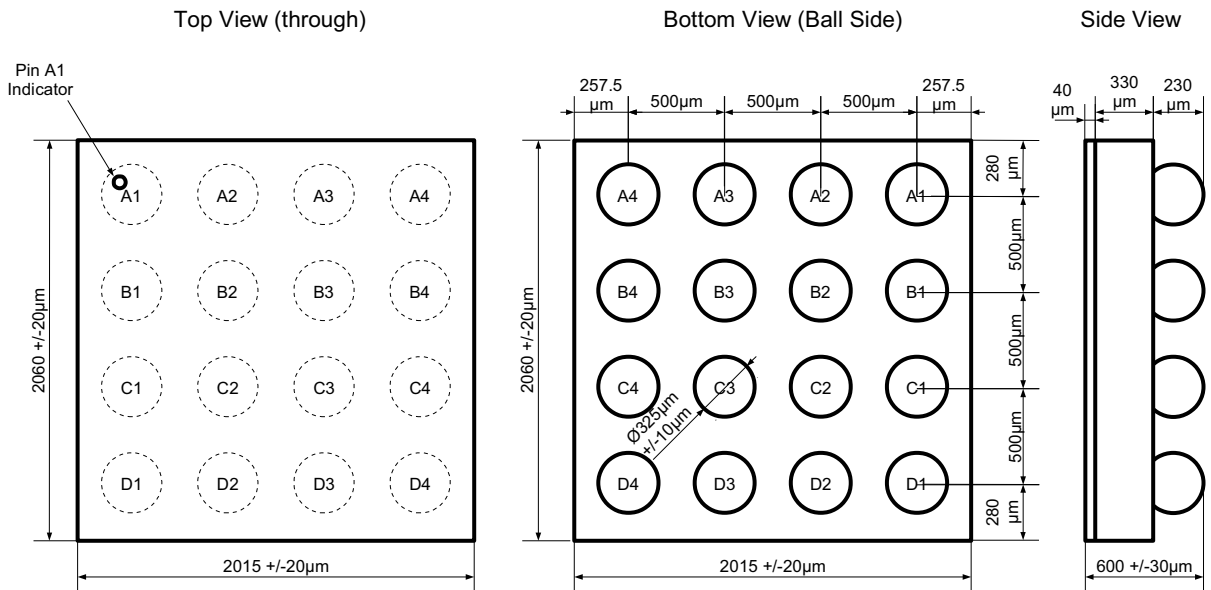

The coplanarity of the balls is 40µm.





11 Ordering Information

The devices are available as the standard products shown in [Table 28](#).

Table 28. Ordering Information

Ordering Code	Description	Delivery Form	Package
AS3649-ZWLT	2500mA High Current LED Flash Driver	Tape & Reel	16-pin WL-CSP (2.06x2.02x0.6mm) 0.5mm pitch RoHS compliant / Pb-Free / Green

Z Temperature Range: -30°C - 85°C

WL Package: Wafer Level Chip Scale Package (WL-CSP) 2.06x2.02x0.6mm

T Delivery Form: Tape & Reel

Note: All products are RoHS compliant and ams green.
Buy our products or get free samples online at www.ams.com/ICdirect

Technical Support is available at www.ams.com/Technical-Support

For further information and requests, email us at sales@ams.com
(or) find your local distributor at www.ams.com/distributor



Copyrights

Copyright © 1997-2013, ams AG, Tobelbaderstrasse 30, 8141 Unterpremstaetten, Austria-Europe. Trademarks Registered ®. All rights reserved. The material herein may not be reproduced, adapted, merged, translated, stored, or used without the prior written consent of the copyright owner.

All products and companies mentioned are trademarks or registered trademarks of their respective companies.

Disclaimer

Devices sold by ams AG are covered by the warranty and patent indemnification provisions appearing in its Term of Sale. ams AG makes no warranty, express, statutory, implied, or by description regarding the information set forth herein or regarding the freedom of the described devices from patent infringement. ams AG reserves the right to change specifications and prices at any time and without notice. Therefore, prior to designing this product into a system, it is necessary to check with ams AG for current information. This product is intended for use in normal commercial applications. Applications requiring extended temperature range, unusual environmental requirements, or high reliability applications, such as military, medical life-support or life-sustaining equipment are specifically not recommended without additional processing by ams AG for each application. For shipments of less than 100 parts the manufacturing flow might show deviations from the standard production flow, such as test flow or test location.

The information furnished here by ams AG is believed to be correct and accurate. However, ams AG shall not be liable to recipient or any third party for any damages, including but not limited to personal injury, property damage, loss of profits, loss of use, interruption of business or indirect, special, incidental or consequential damages, of any kind, in connection with or arising out of the furnishing, performance or use of the technical data herein. No obligation or liability to recipient or any third party shall arise or flow out of ams AG rendering of technical or other services.



Contact Information

Headquarters

ams AG
Tobelbaderstrasse 30
A-8141 Unterpremstaetten, Austria

Tel : +43 (0) 3136 500 0
Fax : +43 (0) 3136 525 01

For Sales Offices, Distributors and Representatives, please visit:

<http://www.ams.com/contact>