

2578 - * - * * *
 MATERIAL CODE
 (.28)/.0106 THK
 BLANK=BRASS
 B=PHOS BRONZE
 WINDING SPEC.
 A=CHAIN, PER WINDING DETAIL "A"
 BLANK=CHAIN, PER WINDING DETAIL "B"
 L=LOOSE

PLATING CODE
 (PER SDES-88)
 (122) - OVERALL TIN: (0.00381)/.000150 MIN.
 OVER (0.00076)/.000030 MIN. NICKEL
 (154) - OVERALL TIN (0.00254)/.000100 MIN.
 OVER (0.00127)/.000050 MIN. NICKEL
 (224) - OVERALL MATTE TIN: (0.00508)/.000200 MIN.
 OVER (0.00127)/.000050 MIN. NICKEL
 (550) - SELECT GOLD: (0.00038)/.000015 MIN.
 OVERALL GOLD FLASH: (0.00005)/.000002 MIN.
 OVERALL NICKEL UNDERPLATE: (0.00076)/.000030 MIN.
 (555) - SELECT GOLD: (0.00038)/.000015 MIN.
 OVERALL NICKEL UNDERPLATE: (0.00076)/.000030 MIN.
 (558) - SELECT GOLD: (0.00076)/.000030 MIN.
 OVERALL GOLD FLASH: (0.00005)/.000002 MIN.
 OVERALL NICKEL UNDERPLATE: (0.00127)/.000050 MIN.
 (P909) - OVERALL HOT TIN DIP: (0.00254)/.000100 MIN

OPTIONS
 BLANK=AS SHOWN
 1 = WITH CAT EARS

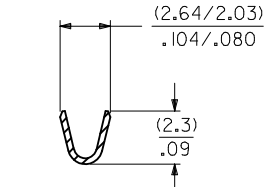
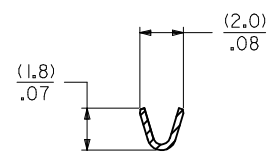
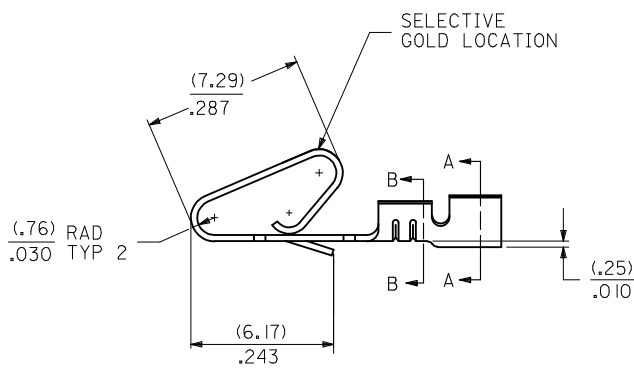
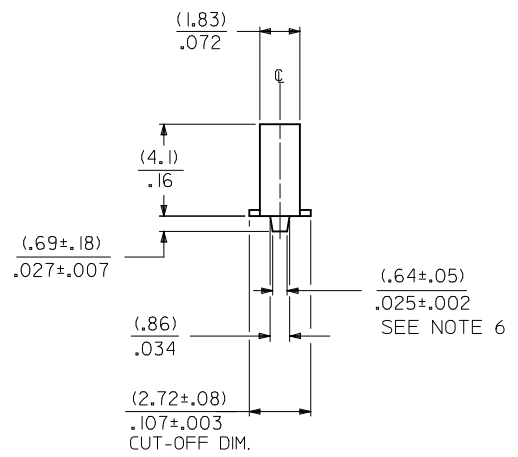

1. MATERIAL: SEE LEGEND
2. FINISH: SEE LEGEND
3. PRODUCT SPECIFICATION: PS-08-50
4. CRIMP ACCEPTS 22 TO 26 GA. WIRE WITH (1.65)/0.65 MAX INSULATION DIA.
5. DIMENSIONS GIVEN ACROSS CENTERLINES ARE SYMMETRICAL ABOUT THOSE CENTERLINES WITHIN HALF THE TOTAL TOLERANCE.
6. OPTIONAL DESIGN (.86±.05)/.034±.002
7. THIS PART CONFORMS TO CLASS B REQUIREMENTS OF COSMETIC SPECIFICATION PS-45499-002

REMOVE OBSOLETE EC NO: UCP2017-0836 DRW:WKIPPER 2016/10/13 CHKD:JFOX 2016/10/17 APPR:FSMITH 2016/11/18	QUALITY SYMBOLS	DESCRIPTION
	▽=0	
	▽=0	
	▽=0	
REV: Y		

GENERAL TOLERANCES (UNLESS SPECIFIED)	
mm	INCH
4 PLACES ± --- ± ---	± .010
3 PLACES ± --- ± ---	± .014
2 PLACES ± 0.25 ± ---	± .036
1 PLACE ± 0.36 ± ---	± ---
0 PLACE ± --- ± ---	
ANGULAR ±1/2°	
DRAFT WHERE APPLICABLE MUST REMAIN WITHIN DIMENSIONS	

DIMENSION STYLE		SCALE	DESIGN UNITS	THIRD ANGLE PROJECTION
MM/IN		---	INCH	
DRAWN BY	DATE	TITLE		
PEREZ/AR	01/29/87	CRIMP TERMINAL (3.96)/.156 CENTERS 22 TO 26 GA WIRE molex		
CHECKED BY	DATE			
PATEL	01/29/87			
APPROVED BY	DATE			
FSMITH	2014/04/21	MATERIAL NO.	DOCUMENT NO.	SHEET NO.
SEE CHART		SD-2578		1 OF 2

THIS DRAWING CONTAINS INFORMATION THAT IS PROPRIETARY TO MOLEX INCORPORATED AND SHOULD NOT BE USED WITHOUT WRITTEN PERMISSION

2578-(****)*		2578-B-(****)*	
PART NO.	ENG. NO.	PART NO.	ENG. NO.
08-50-0107	2578-(P909)	08-50-0133	2578-B-(P909)
08-50-0108	2578-(P909)L	08-50-0134	2578-B-(P909)L
08-50-0111	2578-(154)	08-65-0116	2578-B-(555)
08-50-0112	2578-(154)L	08-65-0117	2578-B-(555)L
08-56-0107	2578-(550)	08-60-0003	2578-B-(122)
08-56-0108	2578-(550)L	08-60-0004	2578-B-(122)L
08-55-0105	2578-(555)	08-65-0110	2578-B-(558)
08-55-0106	2578-(555)L	08-65-0111	2578-B-(558)L
08-50-0061	2578-(224)	08-58-0125	2578-B-(550)
08-50-0062	2578-(224)L	08-58-0126	2578-B-(550)L
08-55-0137	2578-(558)A		
08-55-0123	2578-(558)		

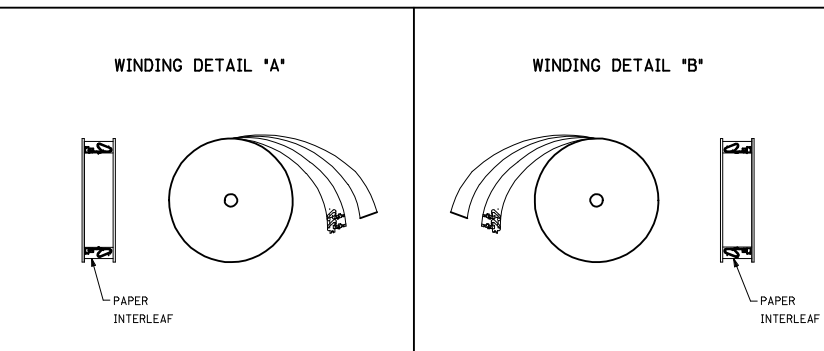
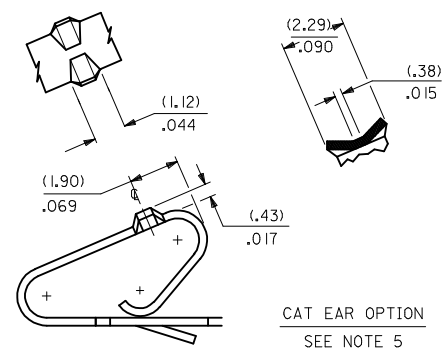

SEE SHEET 1 EC NO: UCP2017-0836 DRWN:MKIPPER 2016/10/13 CHKD:JDOX 2016/10/17 APPR:FSMITH 2016/11/18	QUALITY SYMBOLS
	DESCRIPTION Y

GENERAL TOLERANCES (UNLESS SPECIFIED)	
mm	INCH
4 PLACES ± .005	± .0005
3 PLACES ± .008	± .0008
2 PLACES ± 0.25	± .010
1 PLACE ± 0.36	± .014
0 PLACE ± .005	± .0005
ANGULAR ±1/2°	
DRAFT WHERE APPLICABLE MUST REMAIN WITHIN DIMENSIONS	

DIMENSION STYLE	
MM/IN	DATE
DRAWN BY PEREZ/AR	01/29/87
CHECKED BY PATEL	01/29/87
APPROVED BY FSMITH	2014/04/21
MATERIAL NO.	
SEE CHART	
SIZE C	

SCALE ---	DESIGN UNITS INCH	THIRD ANGLE PROJECTION
CRIMP TERMINAL (3.96)/.156 CENTERS 22 TO 26 GA WIRE 		
DOCUMENT NO. SD-2578	SHEET NO. 2 OF 2	