

Placement of CCE

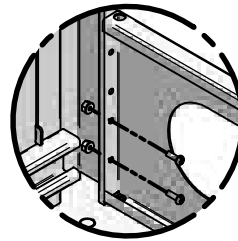

DETAIL B

Holes to knock out

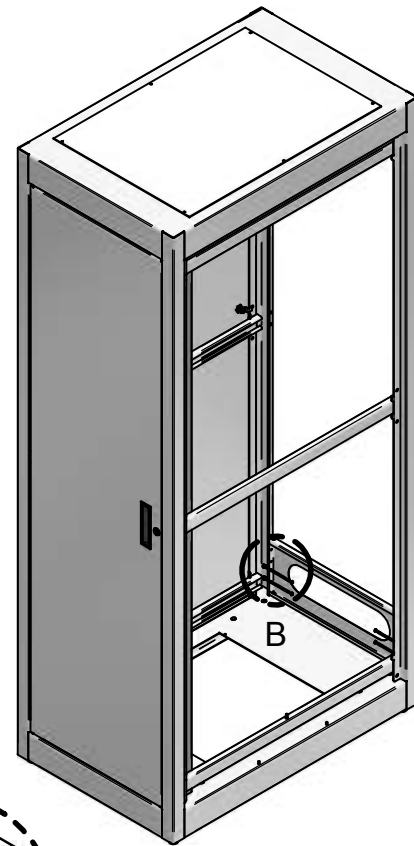
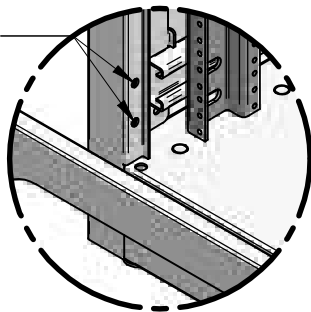

DETAIL A

ASSEMBLY INSTRUCTIONS:

- A) Ensure all parts are available. See BOM list.
- B) Remove the 4 knock out holes located at the bottom of frame opening (use proper striking tool). Detail A shows location of knock out holes
- C) Line up CCE at the base of the cabinet so the holes line up with the K.O. holes. Install screws supplied from the inside of the CCE and fasten using nut supplied (Detail B).
- D) If additional support is desired, then drill one 1/4" hole on each side using CCE as a template and fasten additional hardware supplied

PARTS LIST

ITEM No.	DESCRIPTION	QTY
1	CCE---BK1	1
2	SCREW 8-32 X 1/2 LG	6
3	NUT 8-32 KEPS	6

TOOL BOX



Flat Head
Screw Driver



Hammer



Striking
Tool



HAMMOND
MANUFACTURING™
ELECTRONICS GROUP

visit our website @ www.hammondmfg.com