

PX-2 SERIES

Related Information

- General terms and conditions..... F.17
- Sensor selection guide..... P.831~
- Glossary of terms..... P.1359~
- General precautions..... P.1405



Compact size sensor realizes wide sensing area & long sensing range

Ideal sensing area with very little null zone

The advanced optical system of the **PX-2** series reduces the null zones in front of an automatic guided vehicle (AGV). The null zones at the sides are further minimized if auxiliary sensors which can be easily mounted with connectors are used.
(For **PX-24**, **PX-24ES**, **PX-23ES** and **PX-26**)

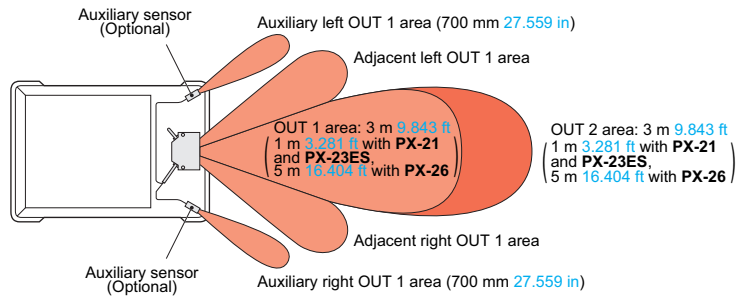

Sensing areas selectable as per route condition

Sensing areas can be selected with switches to suit the route conditions of an AGV. Further, in case of **PX-24ES** and **PX-23ES**, the sensing areas can also be selected with external signals.

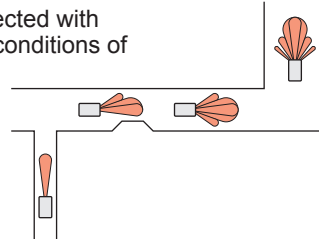

Compact size for space-saving

Its size is half of a conventional model, and the attached cable orientation is freely adjustable. Hence, it can also fit in a small AGV. Moreover, sensitivity adjustment can be done on the front face.

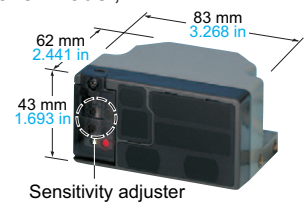

Long sensing range 5 m 16.404 ft type

PX-26 has a long sensing range of 5 m 16.404 ft. Even on a high-speed AGV, it can detect an object quite early so that slowing down and stopping are smooth.

Automatic interference prevention function

One **PX-2** sensor can simultaneously receive beams from 25 Nos. of other **PX-2** sensors without resulting in any interference. Even if AGVs are facing each other, the **PX-2** sensor on one AGV reliably detects the other AGVs. Hence, it can be safely used even at a place where several AGVs are moving.

Sleep function

The sensor can be put into the sleep (stand-by) condition when it is not used and can be restored to operating condition by an external signal. Consequently battery is conserved as the power consumption is reduced to 1/5.

External sensitivity adjustment

The sensitivity of the sensor can be adjusted, within the range set by the manual adjuster, by an external input. (For **PX-24**, **PX-24ES**, **PX-23ES** and **PX-26**)

Selection Guide
Wafer Detection
Liquid Leak Detection
Liquid Level Detection
Water Detection
Color Mark Detection
Hot Melt Glue Detection
Ultrasonic
Small / Slim Object Detection
Obstacle Detection
Other Products

ORDER GUIDE

Main Sensor

Type	Appearance	Sensing range	Model No.
Standard type		3 m 9.843 ft	PX-22
		1 m 3.281 ft	PX-21
Auxiliary sensor connectable type		3 m 9.843 ft	PX-24
		3 m 9.843 ft	PX-24ES
		1 m 3.281 ft	PX-23ES
		5 m 16.404 ft	PX-26
Auxiliary sensor		700 mm 27.559 in	PX-SB1

Accessories

- **MS-PX-2** (Main sensor mounting bracket)

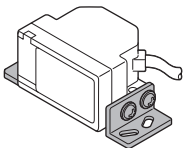

Two bracket set
Four M4 (length 8 mm 0.315 in) screws with washers are attached.

- **MS-NX5-1** (Auxiliary sensor mounting bracket)

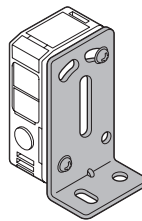

Two M4 (length 25 mm 0.984 in) screws with washers and two M4 nuts are attached.

OPTIONS

Designation	Model No.	Description
Auxiliary sensor mounting bracket	MS-NX5-2	Foot biangled mounting bracket (Sensor protection bracket)
	MS-NX5-3	Back angled mounting bracket

Auxiliary sensor mounting bracket

- **MS-NX5-2**

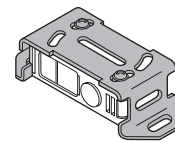

Two M4 (length 25 mm 0.984 in) screws with washers and two M4 nuts are attached.

- **MS-NX5-3**

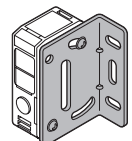

Two M4 (length 25 mm 0.984 in) screws with washers and two M4 nuts are attached.

FIBER SENSORS

LASER SENSORS

PHOTO-ELECTRIC SENSORS

MICRO PHOTO-ELECTRIC SENSORS

AREA SENSORS

LIGHT CURTAINS

PRESSURE / FLOW SENSORS

INDUCTIVE PROXIMITY SENSORS

PARTICULAR USE SENSORS

SENSOR OPTIONS

SIMPLE WIRE-SAVING UNITS

WIRE-SAVING SYSTEMS

MEASUREMENT SENSORS

STATIC CONTROL DEVICES

ENDOSCOPE

LASER MARKERS

PLC / TERMINALS

HUMAN MACHINE INTERFACES

ENERGY CONSUMPTION VISUALIZATION COMPONENTS

FA COMPONENTS

MACHINE VISION SYSTEMS

UV CURING SYSTEMS

Selection Guide

Wafer Detection

Liquid Leak Detection

Liquid Level Detection

Water Detection

Color Mark Detection

Hot Melt Glue Detection

Ultrasonic

Small / Slim Object Detection

Obstacle Detection

Other Products

PX-2

SPECIFICATIONS

Main sensors

Type	Standard model	Auxiliary sensor connectable model					
		With external control function			Long sensing range		
Item	Model No.	PX-22	PX-21	PX-24	PX-24ES	PX-23ES	PX-26
Sensing range (OUT 1 and OUT 2 areas) (Note 2)		3 m 9.843 ft	1 m 3.281 ft	3 m 9.843 ft		1 m 3.281 ft	5 m 16.404 ft
Hysteresis (Note 2)		15 % or less of operation distance					
Supply voltage		10 to 31 V DC including ripple					
Power consumption (Note 3)		Under operation: 1.5 W or less, Under sleep condition: 0.3 W or less (without auxiliary sensor)					
OUT1 (OR circuit among the effective center, left, right, adjacent left / right OUT 1 areas and the effective auxiliary left / right areas)		NPN open-collector transistor • Maximum sink current: 100 mA • Applied voltage: 40 V DC or less (between OUT 1 / OUT 2 and 0 V) • Residual voltage: 1.5 V or less (at 100 mA sink current) 0.4 V or less (at 16 mA sink current)					
OUT2 (OR circuit among the effective center, left and right OUT 2 areas)		NPN open-collector transistor • Maximum sink current: 100 mA • Applied voltage: 40 V DC or less (between OUT 1 / OUT 2 and 0 V) • Residual voltage: 1.5 V or less (at 100 mA sink current) 0.4 V or less (at 16 mA sink current)					
Utilization category		DC-12 or DC-13					
Output operation		Selectable either Light-ON or Dark-ON with a switch (Output operation of OUT 1 and OUT 2 is the same.)					
Short-circuit protection		Incorporated					
Extraneous light monitor output		NPN open-collector transistor • Maximum sink current: 100 mA • Applied voltage: 40 V DC or less (between extraneous light monitor output and 0 V) • Residual voltage: 1.5 V or less (at 100 mA sink current) 0.4 V or less (at 16 mA sink current)					
Output operation		ON when modulated beam other than its own (including auxiliary sensor's) light is received					
Short-circuit protection		Incorporated					
Response time		80 ms or less					
Operation indicators	OUT 1 area	Red LED (lights up when the beam is received in the effective OUT 1 areas)					
	OUT 2 area	Yellow LED (lights up when the beam is received in the effective OUT 2 areas)					
Sensitivity adjuster		Continuously variable adjusters (OUT 1, adjacent right OUT 1, adjacent left OUT 1 and OUT 2 areas are adjusted independently.)					
External sensitivity adjustment function		Sensitivity adjustment is possible with an analog input.					
Sensing area		Four sensing areas are selectable with dip switches.			Four sensing areas are selectable with dip switches, and eight sensing areas are selectable with external inputs.		Fixed
Sleep function		Operating / sleep selectable with external input					
Automatic interference prevention function		Optical interference from up to 25 units is prevented.					
Environmental resistance	Pollution degree	3 (Industrial environment)					
	Protection	IP65 (IEC)					
	Ambient temperature	-10 to +55 °C +14 to +131 °F (No dew condensation or icing allowed), Storage: -20 to +70 °C -4 to +158 °F					
	Ambient humidity	35 to 85 % RH, Storage: 35 to 85 % RH					
	Ambient illuminance	Incandescent light: 3,000 lx at the light-receiving face					
	EMC	EN 60947-5-2					
	Voltage withstandability	1,000 V AC for one min. between all supply terminals connected together and enclosure					
Insulation resistance	20 MΩ, or more, with 500 V DC megger between all supply terminals connected together and enclosure						
Vibration resistance	10 to 500 Hz frequency, 3 mm 0.118 in amplitude (20 G max.) in X, Y and Z directions for two hours each						
Shock resistance	500 m/s ² acceleration (50 G approx.) in X, Y and Z directions for three times each						
Emitting element		Infrared LED (Peak emission wavelength: 950 nm 0.037 mil , modulated)					
Material		Enclosure: ABS, Lens: Acrylic, Cover: Polycarbonate					
Cable		0.3 mm ² 5-core cabtyre cable, 0.5 m 1.640 ft long (for input and output)		For input and output: 0.18 mm ² 9-core (PX-24ES and PX-23ES : 12-core) cabtyre cable, 0.5 m 1.640 ft long			For auxiliary sensor connection: 0.18 mm ² 10-core connector attached cabtyre cable, 0.5 m 1.640 ft long
Cable extension		Extension up to total 100 m 328.084 ft (10 m 32.808 ft for auxiliary sensor connection) is possible with 0.3 mm ² , or more, cable.					
Weight		Net weight: 210 g approx. Gross weight: 390 g approx.		Net weight: 220 g approx. Gross weight: 400 g approx.		Net weight: 210 g approx. Gross weight: 390 g approx.	
Accessories		MS-PX-2 (Main sensor mounting bracket): 1 set, Adjusting screwdriver: 1 pc., Matrix chart for sensing areas and external inputs: 1 sheet (PX-24ES and PX-23ES only)					

Notes: 1) Where measurement conditions have not been specified precisely, the conditions used were an ambient temperature of +23 °C **+73.4 °F**.

2) The sensing range is specified for white non-glossy paper (300 × 300 mm **11.811 × 11.811 in**) as the object.

3) Obtain the current consumption by the following calculation.

Current consumption = Power consumption ÷ Supply voltage

(e.g.) When the supply voltage is 12 V, the current consumption (operating condition) is: 1.5 W ÷ 12 V = 0.125 A = 125 mA

FIBER SENSORS
LASER SENSORS
PHOTO-ELECTRIC SENSORS
MICRO PHOTO-ELECTRIC SENSORS
AREA SENSORS
LIGHT CURTAINS
PRESSURE / FLOW SENSORS
INDUCTIVE PROXIMITY SENSORS
PARTICULAR USE SENSORS
SENSOR OPTIONS
SIMPLE WIRE-SAVING UNITS
WIRE-SAVING SYSTEMS
MEASUREMENT SENSORS
STATIC CONTROL DEVICES
ENDOSCOPE
LASER MARKERS
PLC / TERMINALS
HUMAN MACHINE INTERFACES
ENERGY CONSUMPTION VISUALIZATION COMPONENTS
FA COMPONENTS
MACHINE VISION SYSTEMS
UV CURING SYSTEMS
Selection Guide
Wafer Detection
Liquid Leak Detection
Liquid Level Detection
Water Detection
Color Mark Detection
Hot Melt Glue Detection
Ultrasonic
Small / Slim Object Detection
Obstacle Detection
Other Products

SPECIFICATIONS

Auxiliary sensor (Note 2)

Model No.	PX-SB1
Item	
Applicable main sensor	PX-24, PX-24ES, PX-23ES or PX-26
Connectable units	Up to two PX-SB1 's can be connected to one main sensor.
Sensing range (Note 3)	700 mm 27.559 in
Supply voltage	Supplied from the main sensor
Current consumption	Current consumption of the main sensor increases by 30 mA approx. per auxiliary sensor.
Output	OR circuit with the main sensor's OUT 1
Operation indicator	Red LED (lights up when the beam is received)
Sensitivity adjuster	Continuously variable adjuster
Emitting element	Infrared LED (modulated)
Material	Polycarbonate
Cable	0.3 mm ² 5-core cabtyre cable, 2 m 6.562 ft long
Cable extension	Extension up to total 10 m 32.808 ft is possible with 0.3 mm ² , or more, cable.
Weight	Net weight: 130 g approx., Gross weight: 240 g approx
Accessories	MS-NX5-1 (Auxiliary sensor mounting bracket): 1 set, Adjusting screwdriver: 1 pc.

Specifications other than the above are identical with the main sensor.

- Notes: 1) Where measurement conditions have not been specified precisely, the conditions used were an ambient temperature of +20 °C +68 °F.
 2) The auxiliary sensor cannot be used as a stand-alone unit.
 3) The sensing range is specified for white non-glossy paper (300 × 300 mm **11.811 × 11.811 in**) as the object.

I/O CIRCUIT AND WIRING DIAGRAMS

PX-24ES PX-23ES

I/O circuit diagram

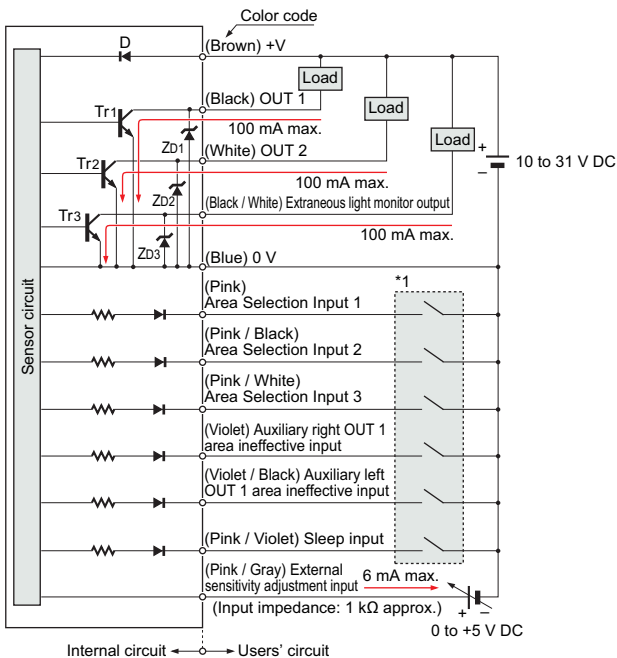

Symbols ... D: Reverse supply polarity protection diode
 ZD1, ZD2, ZD3: Surge absorption zener diode
 Tr1, Tr2, Tr3 : NPN output transistor

Wiring diagram

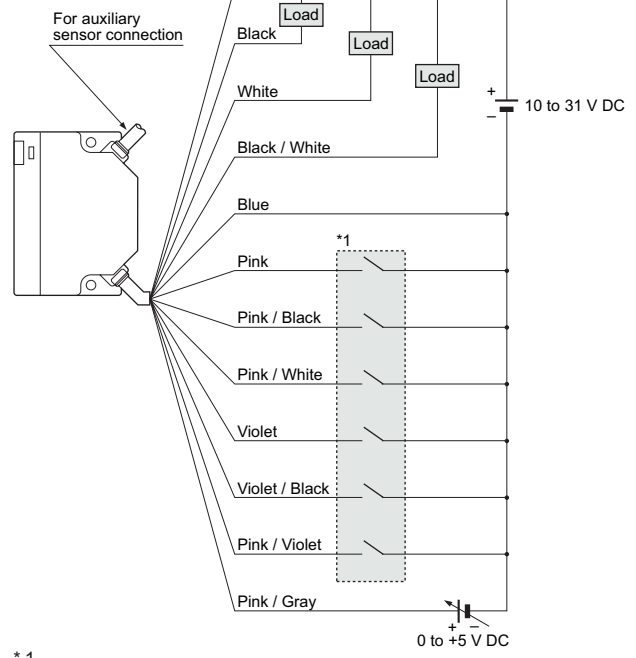

* 1

Non-voltage contact or NPN open-collector transistor

- Area selection input
 Low (0 to 1 V): Depends on the logic combination
 High (4.5 to 31 V, or open): Depends on the logic combination
- Auxiliary area ineffective input
 Low (0 to 1 V): Area ineffective
 High (4.5 to 31 V, or open): Area effective
- Sleep input
 Low (0 to 1 V): Sleep condition
 High [(supply voltage - 1 V) to 31 V, or open]: Operating condition

FIBER SENSORS
 LASER SENSORS
 PHOTO-ELECTRIC SENSORS
 MICRO PHOTO-ELECTRIC SENSORS
 AREA SENSORS
 LIGHT CURTAINS
 PRESSURE / FLOW SENSORS
 INDUCTIVE PROXIMITY SENSORS
 PARTICULAR USE SENSORS
 SENSOR OPTIONS
 SIMPLE WIRE-SAVING UNITS
 WIRE-SAVING SYSTEMS
 MEASUREMENT SENSORS
 STATIC CONTROL DEVICES
 ENDOSCOPE
 LASER MARKERS
 PLC / TERMINALS
 HUMAN MACHINE INTERFACES
 ENERGY CONSUMPTION VISUALIZATION COMPONENTS
 FA COMPONENTS
 MACHINE VISION SYSTEMS
 UV CURING SYSTEMS
 Selection Guide
 Wafer Detection
 Liquid Leak Detection
 Liquid Level Detection
 Water Detection
 Color Mark Detection
 Hot Melt Glue Detection
 Ultrasonic
 Small / Slim Object Detection
 Obstacle Detection
 Other Products

FIBER SENSORS
LASER SENSORS
PHOTO-ELECTRIC SENSORS
MICRO PHOTO-ELECTRIC SENSORS
AREA SENSORS
LIGHT CURTAINS
PRESSURE / FLOW SENSORS
INDUCTIVE PROXIMITY SENSORS
PARTICULAR USE SENSORS
SENSOR OPTIONS
SIMPLE WIRE-SAVING UNITS
WIRE-SAVING SYSTEMS
MEASURE-MENT SENSORS
STATIC CONTROL DEVICES
ENDOSCOPE
LASER MARKERS
PLC/ TERMINALS
HUMAN MACHINE INTERFACES
ENERGY CONSUMPTION VISUALIZATION COMPONENTS
FA COMPONENTS
MACHINE VISION SYSTEMS
UV CURING SYSTEMS
Selection Guide
Wafer Detection
Liquid Leak Detection
Liquid Level Detection
Water Detection
Color Mark Detection
Hot Melt Glue Detection
Ultrasonic
Small / Slim Object Detection
Obstacle Detection
Other Products

I/O CIRCUIT AND WIRING DIAGRAMS

PX-22 PX-21

I/O circuit diagram

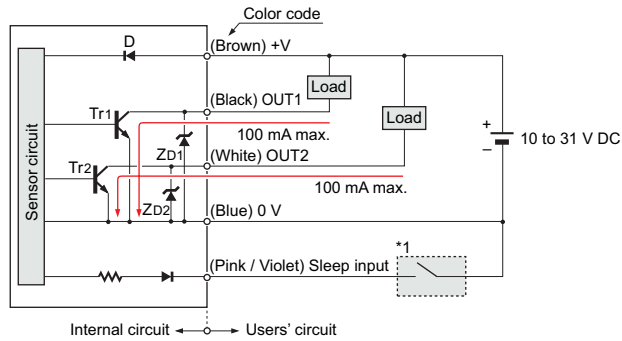

Symbols ... D: Reverse supply polarity protection diode
 ZD1, ZD2: Surge absorption zener diode
 Tr1, Tr2 : NPN output transistor

Wiring diagram

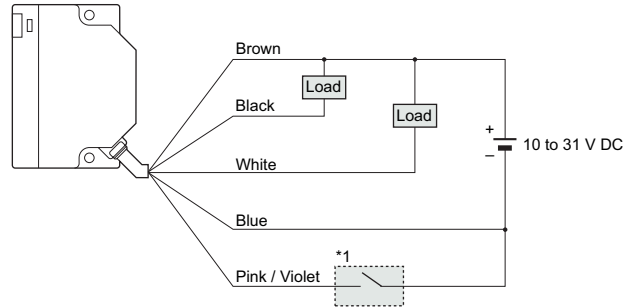

* 1

Non-voltage contact or NPN open-collector transistor

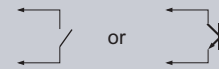

- Sleep input
 Low (0 to 1 V): Sleep condition
 High [(supply voltage - 1 V) to 31 V, or open]: Operating condition

PX-24 PX-26

I/O circuit diagram

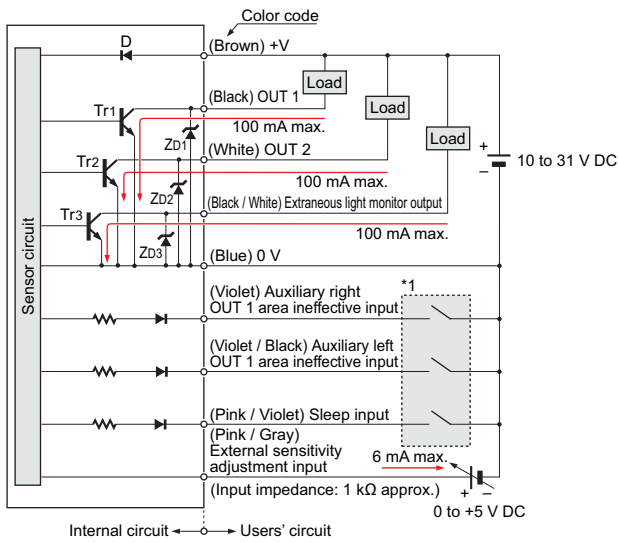

Symbols ... D: Reverse supply polarity protection diode
 ZD1, ZD2, ZD3: Surge absorption zener diode
 Tr1, Tr2, Tr3 : NPN output transistor

Wiring diagram

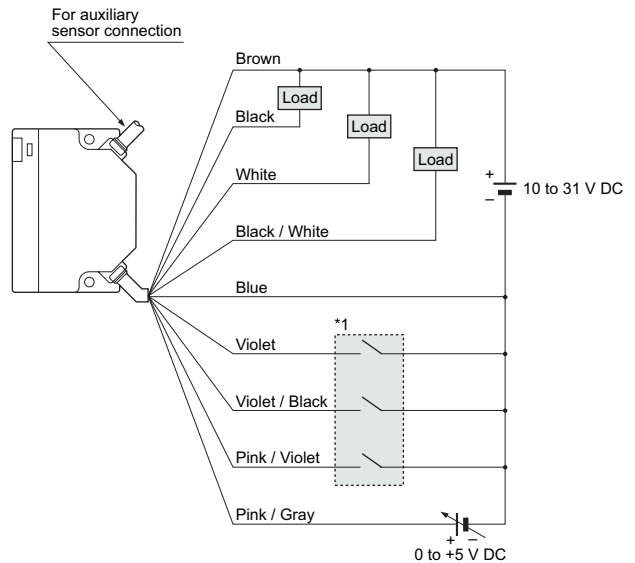

* 1

Non-voltage contact or NPN open-collector transistor

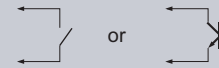

- Auxiliary area ineffective input
 Low (0 to 1 V): Area ineffective
 High (4.5 to 31 V, or open): Area effective
- Sleep input
 Low (0 to 1 V): Sleep condition
 High [(supply voltage - 1 V) to 31 V, or open]: Operating condition

SENSING CHARACTERISTICS (TYPICAL)

How to read sensing characteristics

Sensing field

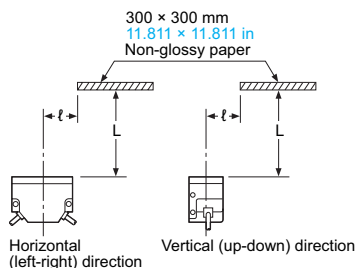

Note: The sensitivity has been adjusted so that the maximum sensing range for white non-glossy paper (300 x 300 mm 11.811 x 11.811 in) is 3 m 9.843 ft (1 m 3.281 ft for PX-21 and PX-23ES, 5 m 16.404 ft for PX-26) with the L., C. and R. areas effective.

Sensing area

- L.: Left area
- C.: Center area
- R.: Right area
- L': Adjacent left OUT 1 area
- R': Adjacent right OUT 1 area

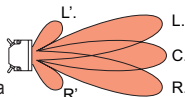

Sensing object

Type of non-glossy paper
White non-glossy paper (lightness: 9)
Gray non-glossy paper (lightness: 5)
Black non-glossy paper (lightness: 2)

Correlation between external sensitivity adjustment input voltage and sensing range

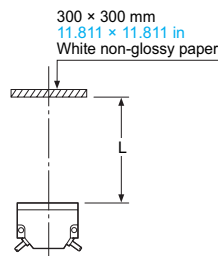

It shows the variation in the sensing range when the external input voltage is changed from 0 to +5 V with the sensitivity adjuster set at the maximum sensing range.

Correlation between sensitivity adjuster and sensing range

Please note that due to the adjuster's characteristics it may be difficult to adjust the sensitivity at a close distance or near to rated sensing distances. (Refer to "Correlation between sensitivity adjuster and sensing range" below.)

All models

Correlation between setting distance and excess gain

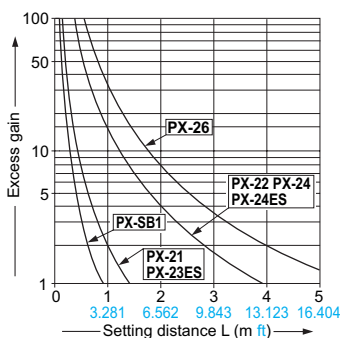

PX-22 PX-24 PX-24ES

Sensing fields

All areas effective (Horizontal)

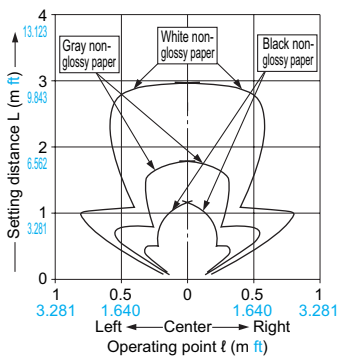

C. area effective (Horizontal)

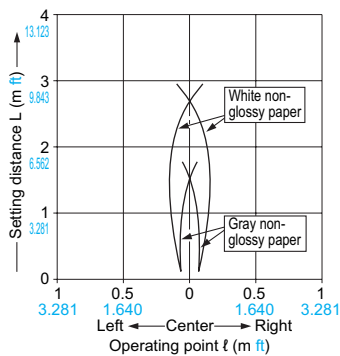

All areas effective (Vertical)

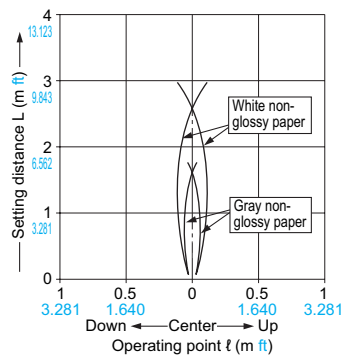

Correlation between external sensitivity adjustment input voltage and sensing range (Excluding PX-22)

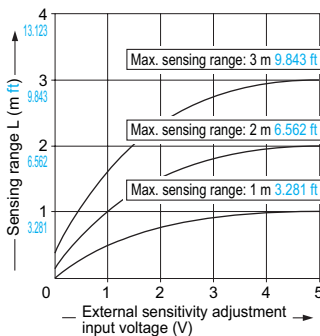

Correlation between sensitivity adjuster and sensing range

OUT1(OUT2) area

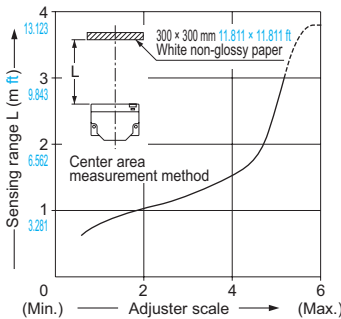

Adjacent right (left) OUT1 area

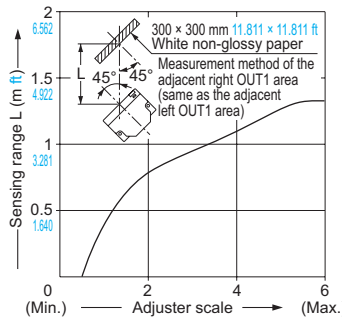

- FIBER SENSORS
- LASER SENSORS
- PHOTO-ELECTRIC SENSORS
- MICRO PHOTO-ELECTRIC SENSORS
- AREA SENSORS
- LIGHT CURTAINS
- PRESSURE / FLOW SENSORS
- INDUCTIVE PROXIMITY SENSORS
- PARTICULAR USE SENSORS
- SENSOR OPTIONS
- SMALL WIRE-SAVING UNITS
- WIRE-SAVING SYSTEMS
- MEASUREMENT SENSORS
- STATIC CONTROL DEVICES
- ENDOSCOPE
- LASER MARKERS
- PLC / TERMINALS
- HUMAN MACHINE INTERFACES
- ENERGY CONSUMPTION VISUALIZATION COMPONENTS
- FA COMPONENTS
- MACHINE VISION SYSTEMS
- UV CURING SYSTEMS
- Selection Guide
- Wafer Detection
- Liquid Leak Detection
- Liquid Level Detection
- Water Detection
- Color Mark Detection
- Hot Melt Glue Detection
- Ultrasonic
- Small / Sim Object Detection
- Obstacle Detection
- Other Products

SENSING CHARACTERISTICS (TYPICAL)

PX-21 PX-23ES

Sensing fields

• All areas effective (Horizontal)

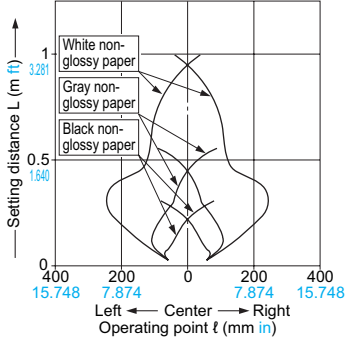

• C. area effective (Horizontal)

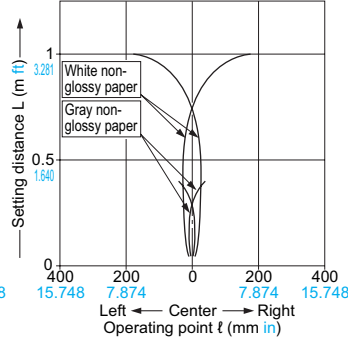

• All areas effective (Vertical)

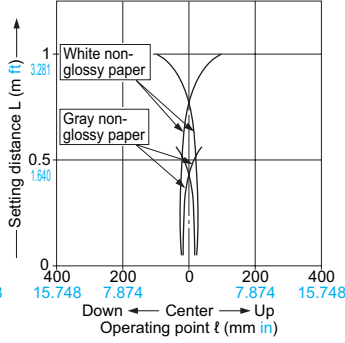

Correlation between external sensitivity adjustment input voltage and sensing range (PX-23ES only)

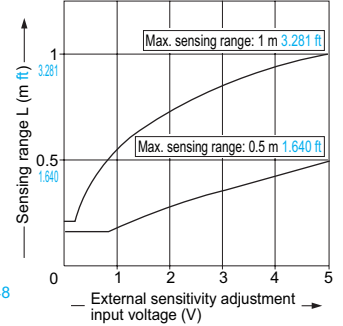

Correlation between sensitivity adjuster and sensing range

• OUT1 (OUT2) area

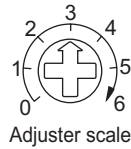
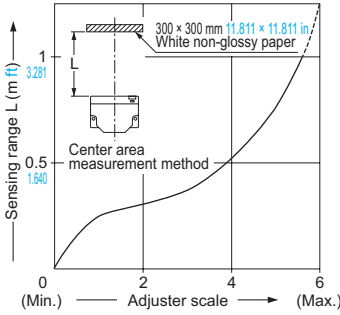

• Adjacent right (left) OUT1 area

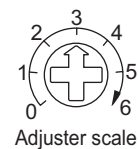
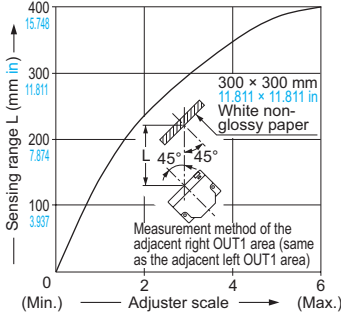

PX-26

Sensing fields

• Horizontal [All areas effective (Note)]

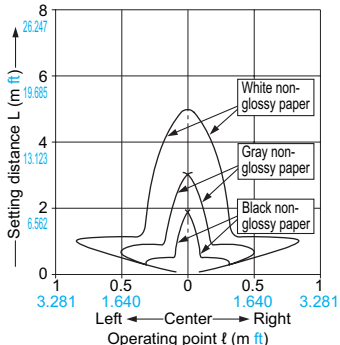

• Vertical [All areas effective (Note)]

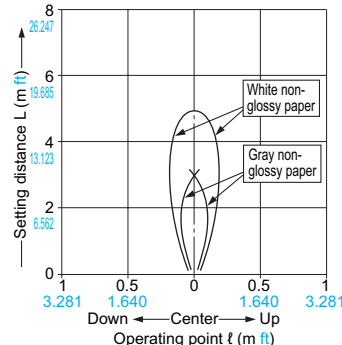

Correlation between external sensitivity adjustment input voltage and sensing range

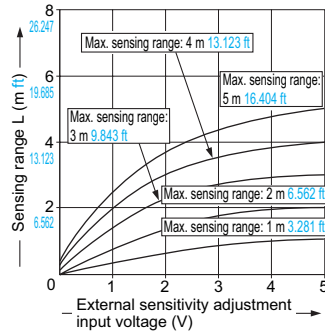

Note: Area selection is not possible.

Correlation between sensitivity adjuster and sensing range

• OUT1 (OUT2) area

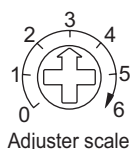
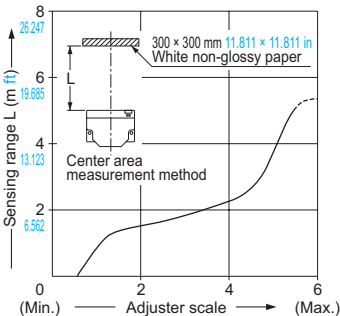

• Adjacent right (left) OUT1 area

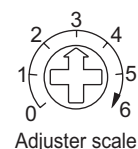
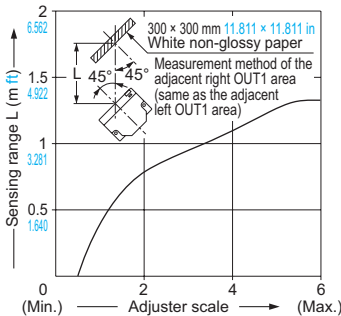

SENSING CHARACTERISTICS (TYPICAL)

PX-SB1

Sensing field

- Horizontal and vertical directions

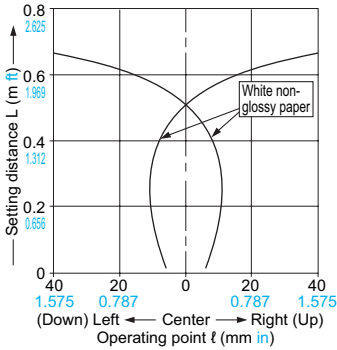

PRECAUTIONS FOR PROPER USE

Refer to General precautions.

All models



- Never use this product as a sensing device for personnel protection.
- In case of using sensing devices for personnel protection, use products which meet laws and standards, such as OSHA, ANSI or IEC etc., for personnel protection applicable in each region or country.

Hazard Indications

In this catalog, **WARNING** and **CAUTION** are indicated depending upon the level of danger. Please observe them strictly for the safe use of this sensor.

WARNING

'WARNING' indicates a potentially hazardous situation that, if not avoided, could result in death or serious injury.

CAUTION

'CAUTION' indicates a hazardous situation that, if not avoided, may result in minor or moderate injury. Further, they also indicate the condition of risk of physical damage to machinery.

WARNING

Installation of a touch bumper

You are requested to always install a touch bumper when this product is used on an automatic guided vehicle (AGV).

CAUTION

Use outside Japan

This sensor conforms to the EMC Directive. However, it is not certified by a competent body in accordance with other country safety standards. Since each country has its regulations, please follow the local and national regulations of the country where this sensor is used.

CAUTION

Fail-safe measures

This sensor is meant for proximity detection and does not possess control functions for safety maintenance. If fail-safe measures are required, consider their incorporation in the total system. Further, do not connect the sensor output directly to a stopping mechanism (brake).

CAUTION

Periodical maintenance check

The person in charge must periodically confirm the performance of the product and maintain a record of such checks. In addition, whenever the operating environment of the product is changed due to system modification, etc., performance check must be done.

Mounting

- The tightening torque for the main sensor should be 1.2 N·m or less.

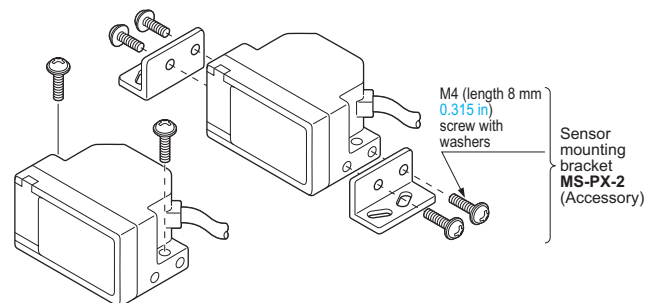

- The tightening torque for **PX-SB1** (auxiliary sensor) should be 0.8 N·m or less.

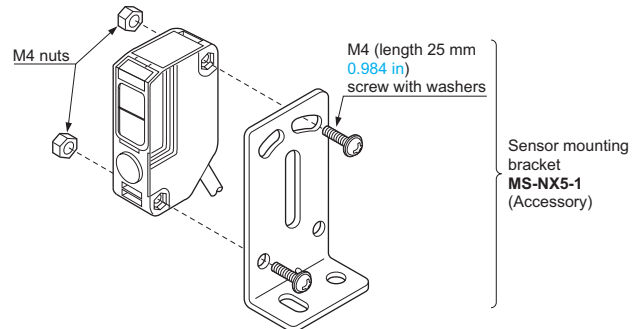

- Mount the sensor, horizontally, at least 300 mm 11.811 in above the floor, to avoid reflection from the floor.

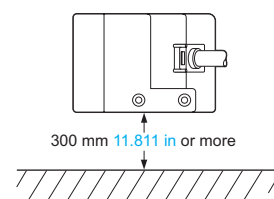

FIBER SENSORS

LASER SENSORS

PHOTO-ELECTRIC SENSORS

MICRO PHOTO-ELECTRIC SENSORS

AREA SENSORS

LIGHT CURTAINS

PRESSURE / FLOW SENSORS

INDUCTIVE PROXIMITY SENSORS

PARTICULAR USE SENSORS

SENSOR OPTIONS

SIMPLE WIRE-SAVING UNITS

WIRE-SAVING SYSTEMS

MEASUREMENT SENSORS

STATIC CONTROL DEVICES

ENDOSCOPE

LASER MARKERS

PLC / TERMINALS

HUMAN MACHINE INTERFACES

ENERGY CONSUMPTION VISUALIZATION COMPONENTS

FA COMPONENTS

MACHINE VISION SYSTEMS

UV CURING SYSTEMS

Selection Guide

Wafer Detection

Liquid Leak Detection

Liquid Level Detection

Water Detection

Color Mark Detection

Hot Melt Glue Detection

Ultrasonic

Small / Slim Object Detection

Obstacle Detection

Other Products

PX-2

PRECAUTIONS FOR PROPER USE

Refer to General precautions.

All models

Automatic interference prevention function

- In case several sensors are used at the same place, take care that the number of sensors from which beams may be simultaneously incident is 25 sensors or less.

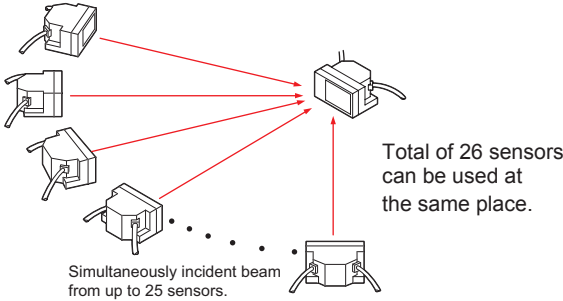

Sleep function (Incorporated in all models)

- When the sleep input is made Low, the sensor goes into the sleep state and the operation can be stopped. Power consumption during the sleep state is 0.3W max. (Without auxiliary sensors).

- Notes:
- 1) Response time of the sleep input is 50ms.
 - 2) Reactivation from the sleep state to the operation state takes 0.7 sec. approx. Operation during this transient state should be avoided.
 - 3) When the sleep function is not used, keep the sleep input wire open or insulated and prevent contact with other wires.

Part description

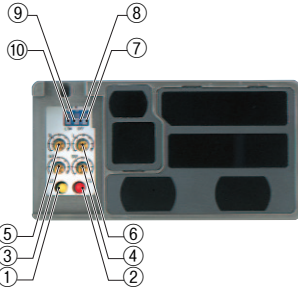

Sign	Item	Description
①	Operation indicator	OUT 2 area (Yellow LED) Lights up when the beam is received in the OUT 2 area.
②		OUT 1 area (Red LED) Lights up when the beam is received in the OUT 1 area.
③	Sensitivity adjuster	OUT 2 area Sensing area sensitivity adjuster.
④		OUT 1 area
⑤		Adjacent right OUT 1 area
⑥	Adjacent left OUT 1 area	
⑦	Sensing area selection switch (Note 1)	Left area Selection of main sensor sensing areas. (OUT 1, OUT 2)
⑧		Right area
⑨	Output operation mode selection switch	Select the operation mode for OUT 1 and OUT 2 with the operation mode selection switch.
⑩	External control function selection switch (Note 2)	Select whether to perform selection of sensing area with the dipswitch or by external input.

Notes: 1) Not incorporated in **PX-26**.
2) Incorporated in **PX-24ES** and **PX-23ES**.

Others

- Do not use during the initial transient time (0.7 sec.) after the power supply is switched on.
- Take care that an initial rush current (1.5 A approx. at 10 V DC and 5 A approx. at 31 V DC) will flow when the power supply is switched on.

PX-22 PX-21 PX-24 PX-24ES PX-23ES

Selection of sensing area

Setting method	Internal settings INT. EXT.	Area selection input (Note) (PX-24ES and PX-23ES only)		
		Input 1	Input 2	Input 3
All areas ineffective	—	L	L	L
Center area effective	—	H	L	L
Center, right and adjacent right OUT 1 areas effective	—	L	H	L
Center left and adjacent left OUT 1 areas effective	—	H	H	L
Center and left / right adjacent OUT 1 areas effective		L	L	H
Center, right and adjacent left / right OUT 1 areas effective		H	L	H
Center, left and adjacent left / right OUT 1 areas effective		L	H	H
All areas effective		H	H	H

L: Low (0 to 1V), H: High (4.5 to 31V, or open)

Note: Response time of area the selection input is 80 ms.

FIBER SENSORS
LASER SENSORS
PHOTO-ELECTRIC SENSORS
MICRO PHOTO-ELECTRIC SENSORS
AREA SENSORS
LIGHT CURTAINS
PRESSURE / FLOW SENSORS
INDUCTIVE PROXIMITY SENSORS
PARTICULAR USE SENSORS
SENSOR OPTIONS
SIMPLE WIRE-SAVING UNITS
WIRE-SAVING SYSTEMS
MEASUREMENT SENSORS
STATIC CONTROL DEVICES
ENDOSCOPE
LASER MARKERS
PLC / TERMINALS
HUMAN MACHINE INTERFACES
ENERGY CONSUMPTION VISUALIZATION COMPONENTS
FA COMPONENTS
MACHINE VISION SYSTEMS
UV CURING SYSTEMS

PRECAUTIONS FOR PROPER USE

Refer to General precautions.

PX-24 PX-24ES PX-23ES PX-26

External sensitivity adjustment function

- The sensitivity can be adjusted, within the range set by the manual sensitivity adjuster, by an analog voltage (0 to +5 V) applied to the external sensitivity adjustment input. The sensitivity varies with the magnitude of the applied voltage.

Notes: 1) The sensitivity of the auxiliary sensor is not changed.
 2) Sensitivity adjustment beyond the range set by the manual sensitivity adjuster is not possible.

Input voltage	0 V ← → +5 V or open
Sensitivity	Minimum ← → Maximum (Maximum sensitivity set by the manual sensitivity adjuster)

3) This wire should be insulated if it is not used.

Extraneous light monitor function

(Not incorporated in **PX-22** and **PX-21**)

- If the sensor receives modulated light other than its own (including auxiliary sensor's) light, the extraneous light monitor output turns ON. The operation of the extraneous light monitor output has absolutely no affect on sensing. It is useful for recognizing presence of other sensors near this sensor in case of intersecting AGV paths, etc.

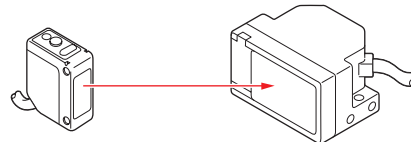

Note: The extraneous light monitor output is not incorporated with a short-circuit protection circuit. Do not connect it directly to a power supply or a capacitive load.

PX-SB1

- This sensor must always be used with the applicable main sensor. This sensor does not work as a standalone unit. (It cannot be used with **PX-22** or **PX-21**.)

Selection of auxiliary area

- Aux area can be selected by aux area ineffective input of the main sensor.

Ineffective input	Auxiliary left OUT 1 area	Auxiliary right OUT 1 area
Sensing area		
Auxiliary left / right OUT 1 area ineffective 	L	L
Auxiliary left OUT 1 area effective 	H	L
Auxiliary right OUT 1 area effective 	L	H
Auxiliary left / right OUT 1 area effective 	H	H

L: Low (0 to 1 V), H: High (4.5 to 31 V or open)
 Note: Aux area disable input has nothing to do with the external control function selection switch of the main sensor.

Sensitivity setting

- Sensitivity adjustment of **PX-SB1** is performed with the emitter volume. If sensitivity cannot be set to close range even after adjusting the emitter volume, then an aux sensor might be receiving the light from the main sensor. If that is the case, adjust sensitivity with the emitter volume and the receiver volume. For details, see the instruction manual that comes with the product.

Connection with the main sensor

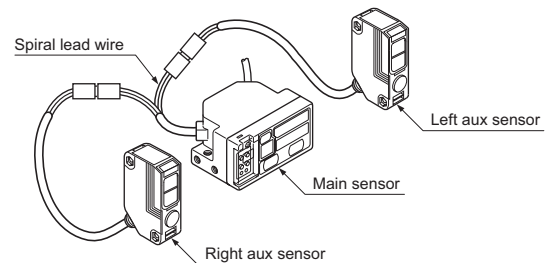

- Connect the main sensor connector attached cable to the aux sensor connector attached cable.
- The spiral lead wire side of the main sensor connector attached cable is the left aux sensor side.

FIBER SENSORS
 LASER SENSORS
 PHOTO-ELECTRIC SENSORS
 MICRO PHOTO-ELECTRIC SENSORS
 AREA SENSORS
 LIGHT CURTAINS
 PRESSURE / FLOW SENSORS
 INDUCTIVE PROXIMITY SENSORS
 PARTICULAR USE SENSORS
 SENSOR OPTIONS
 SIMPLE WIRE-SAVING UNITS
 WIRE-SAVING SYSTEMS
 MEASUREMENT SENSORS
 STATIC CONTROL DEVICES
 ENDOSCOPE
 LASER MARKERS
 PLC / TERMINALS
 HUMAN MACHINE INTERFACES
 ENERGY CONSUMPTION VISUALIZATION COMPONENTS
 FA COMPONENTS
 MACHINE VISION SYSTEMS
 UV CURING SYSTEMS
 Selection Guide
 Wafer Detection
 Liquid Leak Detection
 Liquid Level Detection
 Water Detection
 Color Mark Detection
 Hot Melt Glue Detection
 Ultrasonic
 Small / Slim Object Detection
 Obstacle Detection
 Other Products

DIMENSIONS (Unit: mm in)

The CAD data in the dimensions can be downloaded from our website.

PX-2□

Main sensor

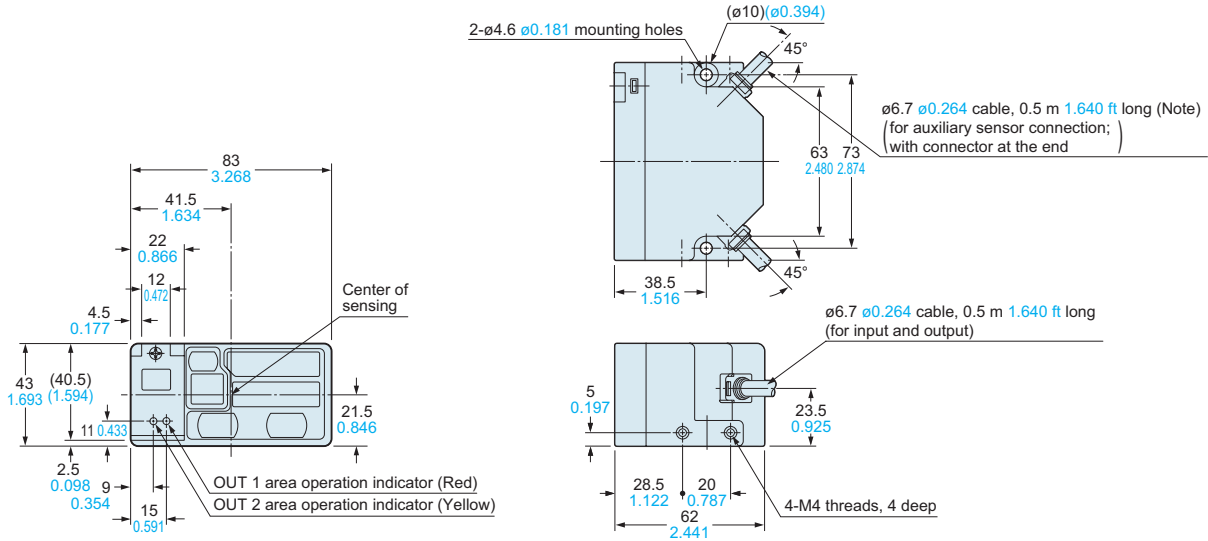

Note: PX-22 and PX-21 do not have this cable.

PX-SB1

Auxiliary sensor

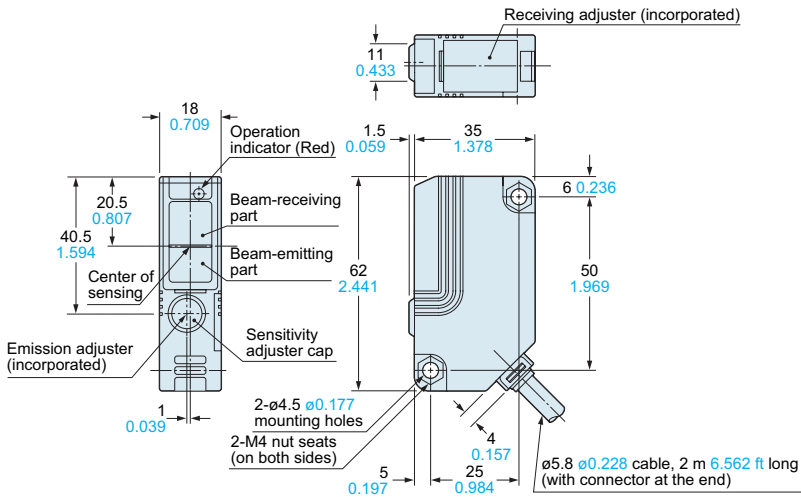

- FIBER SENSORS
- LASER SENSORS
- PHOTO-ELECTRIC SENSORS
- MICRO PHOTO-ELECTRIC SENSORS
- AREA SENSORS
- LIGHT CURTAINS
- PRESSURE / FLOW SENSORS
- INDUCTIVE PROXIMITY SENSORS
- PARTICULAR USE SENSORS
- SENSOR OPTIONS
- SIMPLE WIRE-SAVING UNITS
- WIRE-SAVING SYSTEMS
- MEASUREMENT SENSORS
- STATIC CONTROL DEVICES
- ENDOSCOPE
- LASER MARKERS
- PLC / TERMINALS
- HUMAN MACHINE INTERFACES
- ENERGY CONSUMPTION VISUALIZATION COMPONENTS
- FA COMPONENTS
- MACHINE VISION SYSTEMS
- UV CURING SYSTEMS
- Selection Guide
- Wafer Detection
- Liquid Leak Detection
- Liquid Level Detection
- Water Detection
- Color Mark Detection
- Hot Melt Glue Detection
- Ultrasonic
- Small / Slim Object Detection
- Obstacle Detection
- Other Products

DIMENSIONS (Unit: mm in)

The CAD data in the dimensions can be downloaded from our website.

MS-PX-2

Main sensor mounting bracket (Accessory for PX-2□)

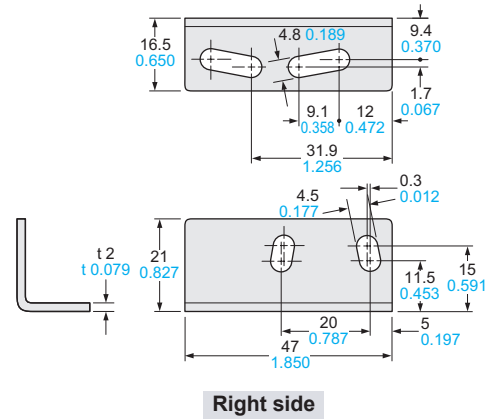
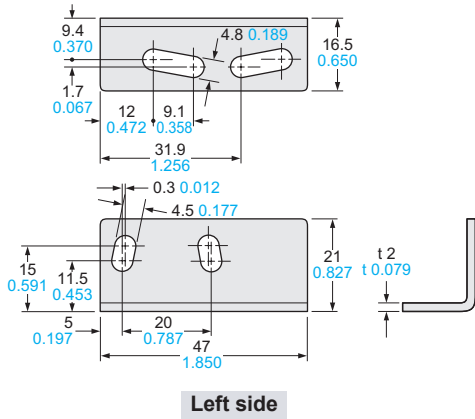

Material: Cold rolled carbon steel (SPCC)
(Uni-chrome plated)

Four M4 (length 8 mm 0.315 in) screws with washers are attached.

Assembly dimensions

Mounting drawing with PX-24

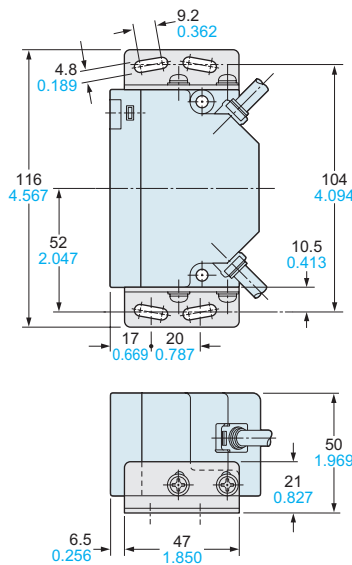
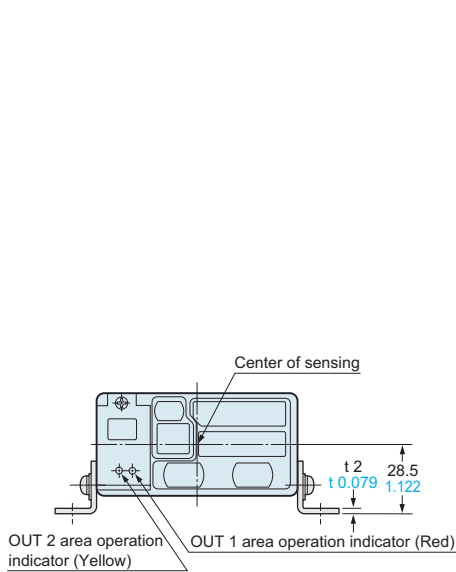

FIBER SENSORS

LASER SENSORS

PHOTO-ELECTRIC SENSORS

MICRO PHOTO-ELECTRIC SENSORS

AREA SENSORS

LIGHT CURTAINS

PRESSURE / FLOW SENSORS

INDUCTIVE PROXIMITY SENSORS

PARTICULAR USE SENSORS

SENSOR OPTIONS

SIMPLE WIRE-SAVING UNITS

WIRE-SAVING SYSTEMS

MEASUREMENT SENSORS

STATIC CONTROL DEVICES

ENDOSCOPE

LASER MARKERS

PLC / TERMINALS

HUMAN MACHINE INTERFACES

ENERGY CONSUMPTION VISUALIZATION COMPONENTS

FA COMPONENTS

MACHINE VISION SYSTEMS

UV CURING SYSTEMS

Selection Guide

Wafer Detection

Liquid Leak Detection

Liquid Level Detection

Water Detection

Color Mark Detection

Hot Melt Glue Detection

Ultrasonic

Small / Slim Object Detection

Obstacle Detection

Other Products

PX-2

- FIBER SENSORS
- LASER SENSORS
- PHOTO-ELECTRIC SENSORS
- MICRO PHOTO-ELECTRIC SENSORS
- AREA SENSORS
- LIGHT CURTAINS
- PRESSURE / FLOW SENSORS
- INDUCTIVE PROXIMITY SENSORS
- PARTICULAR USE SENSORS
- SENSOR OPTIONS
- SIMPLE WIRE-SAVING UNITS
- WIRE-SAVING SYSTEMS
- MEASUREMENT SENSORS
- STATIC CONTROL DEVICES
- ENDOSCOPE
- LASER MARKERS
- PLC / TERMINALS
- HUMAN MACHINE INTERFACES
- ENERGY CONSUMPTION VISUALIZATION COMPONENTS
- FA COMPONENTS
- MACHINE VISION SYSTEMS
- UV CURING SYSTEMS
- Selection Guide
- Wafer Detection
- Liquid Leak Detection
- Liquid Level Detection
- Water Detection
- Color Mark Detection
- Hot Melt Glue Detection
- Ultrasonic
- Small / Slim Object Detection
- Obstacle Detection
- Other Products

DIMENSIONS (Unit: mm in)

The CAD data in the dimensions can be downloaded from our website.

MS-NX5-1

Auxiliary sensor mounting bracket (Accessory for PX-SB1)

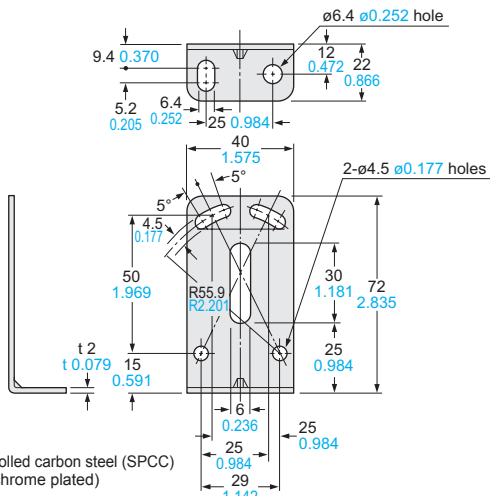

Material: Cold rolled carbon steel (SPCC) (Uni-chrome plated)
Two M4 (length 25 mm 0.984 in) screws with washers and two M4 nuts are attached.

Assembly dimensions

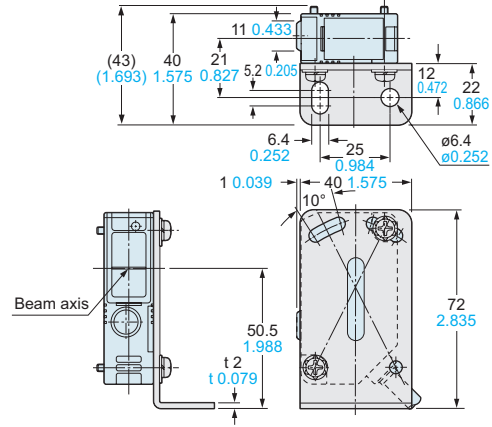

MS-NX5-2

Auxiliary sensor mounting bracket (Optional)

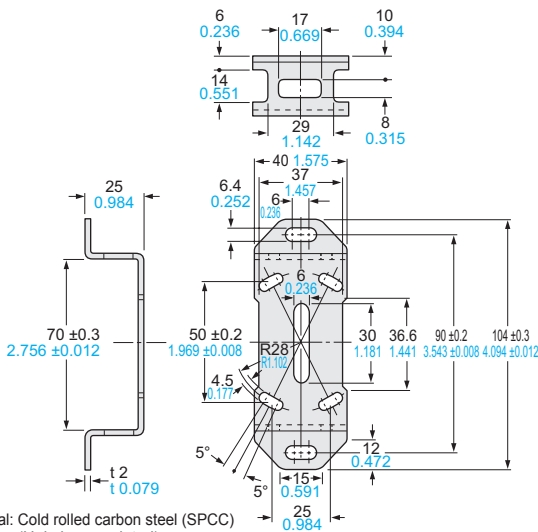

Material: Cold rolled carbon steel (SPCC) (Uni-chrome plated)
Two M4 (length 25 mm 0.984 in) screws with washers and two M4 nuts are attached.

Assembly dimensions

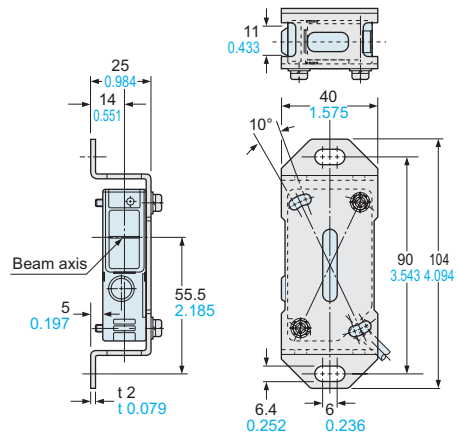

MS-NX5-3

Auxiliary sensor mounting bracket (Optional)

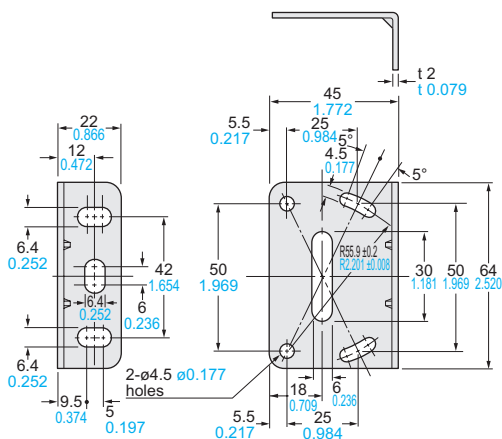

Material: Cold rolled carbon steel (SPCC) (Uni-chrome plated)
Two M4 (length 25 mm 0.984 in) screws with washers and two M4 nuts are attached.

Assembly dimensions

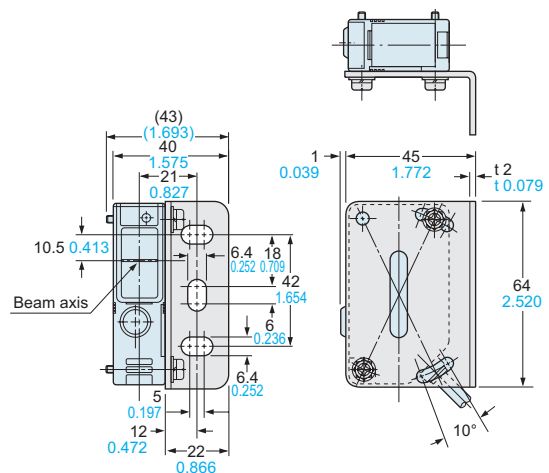

MEMO

