

Current Mode PWM Controller

Description

The SG1842/43 family of control IC's provides all the necessary features to implement off-line fixed frequency, current-mode switching power supplies with a minimum number of external components.

Current-mode architecture demonstrates improved line regulation, improved load regulation, pulse-by-pulse current limiting and inherent protection of the power supply output switch. The bandgap reference is trimmed to $\pm 1\%$ over temperature.

Oscillator discharge current is trimmed to less than $\pm 10\%$. The SG1842/43 has under-voltage lockout, current limiting circuitry and start-up current of less than 1mA. The totem-pole output is optimized to drive the gate of a power MOSFET. The output is low in the off state to provide direct interface to an N-channel device. The SG1842/43 is specified for operation over the full military ambient temperature range of -55°C to 125°C . The SG2842/43 is specified for the industrial range of -25°C to 85°C , and the SG3842/43 is designed for the commercial range of 0°C to 70°C .

Product Highlight

Features

- Optimized For Off-Line Control
- Low Start-Up Current ($<1\text{mA}$)
- Automatic Feed Forward Compensation
- Trimmed Oscillator Discharge Current
- Pulse-By-Pulse Current Limiting
- Enhanced Load Response Characteristics
- Under-Voltage Lockout with 6V Hysteresis (SG1842 only)
- Double-Pulse Suppression
- High-Current Totem-Pole Output (1A Peak)
- Internally Trimmed Bandgap Reference
- 500kHz Operation
- Undervoltage Lockout
SG1842 - 16 volts
SG1843 - 8.4 volts
- Low Shoot-Through Current $<75\text{mA}$ Over Temperature

Application

- Available To MIL-STD – 883, ¶ 1.2.1
- Available to DSCC
- Standard Microcircuit Drawing (SMD)

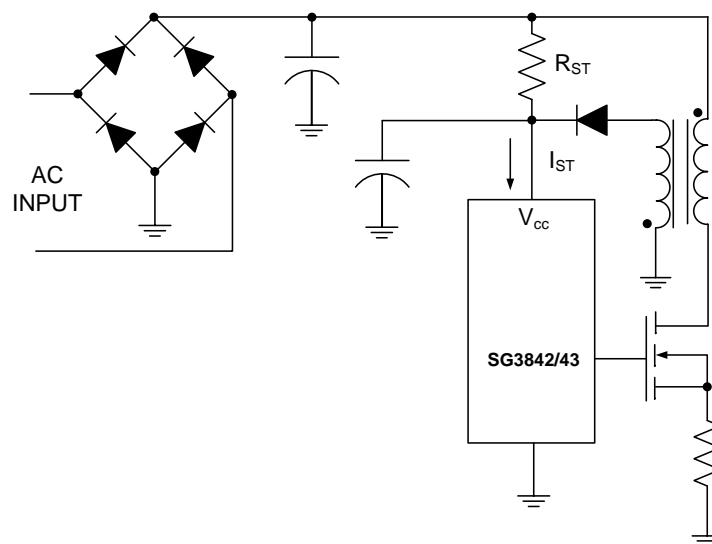
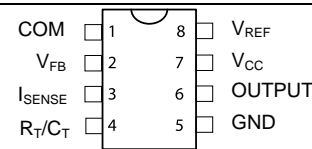
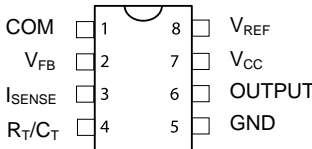
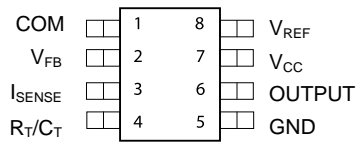
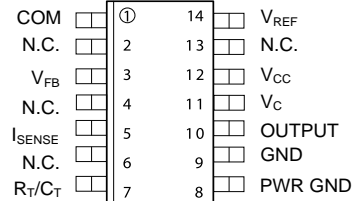
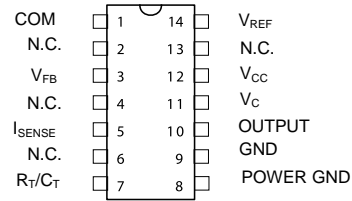

Figure 1 - Product Highlight

Connection Diagrams and Ordering Information

Ambient Temperature	Type	Package	Part Number	Packaging Type	Connection Diagram
0°C to 70°C	M	8-PIN PLASTIC DUAL INLINE PACKAGE	SG3842M	Plastic DIP	 <p>M PACKAGE (Top View)</p> <p>M Package: RoHS / Pb-free 100% Matte Tin Lead Finish</p>
-25°C to 85°C			SG3843M		
			SG2842M		
			SG2843M		
0°C to 70°C	Y	8-PIN CERAMIC DUAL INLINE PACKAGE	SG3842Y	CERDIP	 <p>Y PACKAGE (Top View)</p> <p>PbSn Tin Lead Finish</p>
-25°C to 85°C			SG3843Y		
-55°C to 125°C			SG2842Y		
MIL-STD/883			SG2843Y		
DESC			SG1842Y		
			SG1843Y		
			SG1842Y-883B		
			SG1843Y-883B		
	SG1842Y-DESC				
	SG1843Y-DESC				
0°C to 70°C	DM	8-PIN SMALL OUTLINE INTEGRATED CIRCUIT	SG3842DM	SOIC	 <p>DM PACKAGE (Top View)</p> <p>RoHS / Pb-free 100% Matte Tin Lead Finish</p>
-25°C to 85°C			SG3843DM		
			SG2842DM		
			SG2843DM		
0°C to 70°C	D	14-PIN SMALL OUTLINE INTEGRATED CIRCUIT	SG3842D	SOIC	 <p>D PACKAGE (Top View)</p> <p>RoHS / Pb-free 100% Matte Tin Lead Finish</p>
-25°C to 85°C			SG3843D		
			SG2842D		
			SG2843D		
0°C to 70°C	N	14-PIN DUAL INLINE PLASTIC PACKAGE	SG3842N	PLASTIC DIP	 <p>N PACKAGE (Top View)</p> <p>N Package: RoHS / Pb-free 100% Matte Tin Lead Finish</p>
-25°C to 85°C			SG3843N		
			SG2842N		
			SG2843N		

Connection Diagrams and Ordering Information (continued)

Ambient Temperature	Type	Package	Part Number	Packaging Type	Connection Diagram
-55°C to 125°C	J	14-PIN CERAMIC DUAL INLINE PACKAGE	SG1842J	CERDIP	<p>J PACKAGE (Top View) PbSn Lead Finish</p>
			SG1843J		
MIL-STD/883			SG1842J-883B		
			SG1843J-883B		
DESC			SG1842J-DESC		
			SG1843J-DESC		
-55°C to 125°C	F	10-PIN CERAMIC FLAT PACK PACKAGE	SG1842F	FLAT PACK	<p>F PACKAGE (Top View) PbSn Lead Finish</p>
			SG1843F		
MIL-STD/883			SG1842F-883B		
			SG1843F-883B		
DESC			SG1842F-DESC		
			SG1843F-DESC		
-55°C to 125°C	L	20-PIN CERAMIC	SG1842L	Ceramic Leadless Chip Carrier (LCC)	<p>L PACKAGE (Top View) PbSn Lead Finish</p>
			SG1843L		
MIL-STD/883			SG1842L-883B		
			SG1843L-883B		
DESC			SG1842L-DESC		
			SG1843L-DESC		

Notes:

- Contact factory for JAN and DESC part availability.
- All parts are viewed from the top.
- Available in Tape & Reel. Append the letters "TR" to the part number (SG3842N-TR).

Absolute Maximum Ratings^{1 - 2}

Parameter	Value	Units
Supply Voltage ($I_{CC} < 30\text{mA}$)	Self-limiting	V
Supply Voltage (Low Impedance Source)	30	V
Output Current (Peak)	± 1	A
Output Current (Continuous)	350	mA
Output Energy (Capacitive Load)	5	μJ
Analog Inputs (V_{FB} , I_{SENSE})	-0.3 to +6.3	V
Error Amplifier Output Sink Current	10	mA
Power Dissipation at $T_A = 25^\circ\text{C}$ (DIL-8)	1	W
Operating Junction Temperature		
Hermetic (J, Y, F, L Packages)	150	$^\circ\text{C}$
Plastic (N, M, D, DM Packages)	150	$^\circ\text{C}$
Storage Temperature Range	-65 to +150	$^\circ\text{C}$
Lead Temperature (Soldering, 10 Seconds)	300	$^\circ\text{C}$
RoHS / Pb-free Peak Package Solder Reflow Temp. (40 second max. exposure)	260 (+0, -5)	$^\circ\text{C}$
<i>Notes:</i>		
1. Exceeding these ratings could cause damage to the device.		
2. All voltages are with respect to Pin 5. All currents are positive into the specified terminal.		

Thermal Data

Parameter	Value	Units
M Package:		
Thermal Resistance-Junction to Ambient, θ_{JA}	95	$^\circ\text{C/W}$
N Package:		
Thermal Resistance-Junction to Ambient, θ_{JA}	65	$^\circ\text{C/W}$
DM Package:		
Thermal Resistance-Junction to Ambient, θ_{JA}	165	$^\circ\text{C/W}$
D Package:		
Thermal Resistance-Junction to Ambient, θ_{JA}	120	$^\circ\text{C/W}$
Y Package:		
Thermal Resistance-Junction to Ambient, θ_{JA}	130	$^\circ\text{C/W}$
J Package		
Thermal Resistance-Junction to Ambient, θ_{JA}	80	$^\circ\text{C/W}$
F Package		
Thermal Resistance-Junction to Case, θ_{JC}	80	$^\circ\text{C/W}$
Thermal Resistance-Junction to Ambient, θ_{JA}	145	$^\circ\text{C/W}$
L Package		
Thermal Resistance-Junction to Case, θ_{JC}	35	$^\circ\text{C/W}$
Thermal Resistance-Junction to Ambient, θ_{JA}	120	$^\circ\text{C/W}$
<i>Notes:</i>		
1. Junction Temperature Calculation: $T_J = T_A + (P_D \times \theta_{JA})$.		
2. The θ_{JA} numbers are guidelines for the thermal performance of the device/pc-board system. All of the above assume no ambient airflow.		

Recommended Operating Conditions

Symbol	Parameter	Recommended Operating Conditions			Units
		Min	Typ	Max	
V _S	Supply Voltage Range		30		V
I _{PK}	Output Current (Peak)		±1		A
I _{OUT}	Output Current (Continuous)		200		mA
	Analog Inputs (V _{FB} , I _{SENSE})	0		2.6	V
E _{ASINK}	Error Amp Output Sink Current		5		mA
OSC _{FR}	Oscillator Frequency Range	0.1		500	kHz
R _T	Oscillator Timing Resistor	0.52		150	kΩ
C _T	Oscillator Timing Capacitor	0.001		1.0	μF
Operating Ambient Temperature Range					
	SG1842/43	-55		125	°C
	SG2842/43	-25		85	°C
	SG3842/43	0		70	°C
<i>Note: Range over which the device is functional.</i>					

Electrical Characteristics

Unless otherwise specified, these specifications apply over the operating ambient temperatures for SG1842/SG1843 with $-55^{\circ}\text{C} \leq T_A \leq 125^{\circ}\text{C}$, SG2842/SG2843 with $-25^{\circ}\text{C} \leq T_A \leq 85^{\circ}\text{C}$, SG3842/SG3843 with $0^{\circ}\text{C} \leq T_A \leq 70^{\circ}\text{C}$, $V_{CC} = 15\text{V}$, $R_T = 10\text{k}\Omega$, and $C_T = 3.3\text{nF}$. Low duty cycle pulse testing techniques are used which maintains junction and case temperatures equal to the ambient temperature.

Symbol	Parameter	Test Conditions	SG1842/43			SG2842/43			SG3842/43			Units
			Min	Typ	Max	Min	Typ	Max	Min	Typ	Max	
Reference Section												
V_{REF}	Output Voltage	$T_J = 25^{\circ}\text{C}$, $I_O = 1\text{mA}$	4.95	5.00	5.05	4.95	5.00	5.05	4.90	5.00	5.10	V
V_{REG}	Line Regulation	$12\text{V} \leq V_{IN} \leq 25\text{V}$		6	20		6	20		6	20	mV
I_{REG}	Load Regulation	$1 \leq I_O \leq 20\text{mA}$		6	25		6	25		6	25	mV
	Temperature Stability ¹			0.2	0.4		0.2	0.4		0.2	0.4	mV/ $^{\circ}\text{C}$
	Total Output Variation ¹	Line, Load, Temperature	4.90		5.10	4.90		5.10	4.82		5.18	V
V_N	Output Noise Voltage ¹	$10\text{Hz} \leq f \leq 10\text{kHz}$, $T_J = 25^{\circ}\text{C}$		50			50			50		μV
	Long Term Stability ¹	$T_A = 125^{\circ}\text{C}$, 1000hrs		5	25		5	25		5	25	mV
V_{REFOSC}	Output Short Circuit		-30	-100	-180	-30	-100	-180	-30	-100	-180	mA
Oscillator Section³												
f	Initial Accuracy ⁵	$T_J = 25^{\circ}\text{C}$	47	52	57	47	52	57	47	52	57	kHz
f_{REG}	Voltage Stability	$12\text{V} \leq V_{CC} \leq 25\text{V}$		0.2	1		0.2	1		0.2	1	%
	Temperature Stability ¹	$T_{MIN} \leq T_A \leq T_{MAX}$		5			5			5		%
OSC_{PP}	Amplitude	$V_{RT/CT}$ (Peak to Peak)		1.7			1.7			1.7		V
I_{DSG}	Discharge Current	$T_J = 25^{\circ}\text{C}$	7.8	8.3	8.8	7.5	8.4	9.3	7.5	8.4	9.3	mA
		$T_{MIN} \leq T_A \leq T_{MAX}$	7.0		9.0	7.2		9.5	7.2		9.5	mA
Error Amp Section												
EA_{IN}	Input Voltage	$V_{COMP} = 2.5\text{V}$	2.45	2.50	2.55	2.45	2.50	2.55	2.42	2.50	2.58	V
EA_{IB}	Input Bias Current			-0.3	-1		-0.3	1		-0.3	-2	μA
A_{VOL}	Open Loop Gain	$2\text{V} \leq V_O \leq 4\text{V}$	65	90		65	90		65	90		dB
EA_{BW}	Unity Gain Bandwidth ¹	$T_J = 25^{\circ}\text{C}$	0.7	1		0.7	1		0.7	1		MHz
PSRR	Power Supply Rejection Ratio	$12\text{V} \leq V_{CC} \leq 25\text{V}$	60	70		60	70		60	70		dB
EA_{SINK}	Output Sink Current	$V_{VFB} = 2.7\text{V}$, $V_{COMP} = 1.1\text{V}$	2	6		2	6		2	6		mA
EA_{SRC}	Output Source Current	$V_{VFB} = 2.3\text{V}$, $V_{COMP} = 5\text{V}$	-0.5	-0.8		-0.5	-0.8		-0.5	-0.8		mA
EA_{VOH}	V_{OUT} High	$V_{VFB} = 2.3\text{V}$, $R_L = 15\text{k to GND}$	5	6		5	6		5	6		V
EA_{VOL}	V_{OUT} Low	$V_{VFB} = 2.7\text{V}$, $R_L = 15\text{k to } V_{REF}$		0.7	1.1		0.7	1.1		0.7	1.1	V

Electrical Characteristics (continued)

Symbol	Parameter	Test Conditions	SG1842/43			SG2842/43			SG3842/43			Units
			Min	Typ	Max	Min	Typ	Max	Min	Typ	Max	
Current Sense Section												
CS _{AVOL}	Gain ^{2,3}		2.85	3	3.15	2.85	3	3.15	2.85	3	3.15	V/V
	Maximum Input Signal ²	V _{COMP} = 5V	0.9	1	1.1	0.9	1	1.1	0.9	1	1.1	V
PSRR	Power Supply Rejection Ratio ²	12V ≤ V _{CC} ≤ 25V		70			70			70		dB
CS _{IB}	Input Bias Current			-2	-10		-2	-10		-2	-10	μA
CS _{DELAY}	Delay to Output ¹			150	300		150	300		150	300	ns
Output Section												
V _{OL}	Output Low Level	I _{SINK} = 20mA		0.1	0.4		0.1	0.4		0.1	0.4	V
		I _{SINK} = 200mA		1.5	2.2		1.5	2.2		1.5	2.2	V
V _{OH}	Output High Level	I _{SOURCE} = 20mA	13	13.5		13	13.5		13	13.5		V
		I _{SOURCE} = 200mA	12	13.5		12	13.5		12	13.5		V
R _S	Rise Time	T _J = 25°C, C _L = 1nF		50	150		50	150		50	150	ns
F _T	Fall Time	T _J = 25°C, C _L = 1nF		50	150		50	150		50	150	ns
Under-Voltage Lockout Section												
UVLO	Start Threshold	1842/2842/3842	15	16	17	15	16	17	14.5	16	17.5	V
		1843/2843/3843	7.8	8.4	9.0	7.8	8.4	9.0	7.8	8.4	9.0	V
V _{SMIN}	Min. Operation Voltage After Turn-On	1842/2842/3842	9	10	11	9	10	11	8.5	10	11.5	V
		1843/2843/3843	7.0	7.6	8.3	7.0	7.6	8.2	7.0	7.6	8.2	V
PWM Section												
DC _{MAX}	Maximum Duty Cycle		93	95	100	90	95	100	90	95	100	%
DC _{MIN}	Minimum Duty Cycle				0			0			0	%
Power Consumption Section												
I _S	Start-Up Current			0.5	1		0.5	1		0.5	1	mA
I	Operating Supply Current	V _{FB} = V _{ISENSE} = 0V		11	17		11	17		11	17	mA
Z	V _{CC} Zener Voltage	I _{CC} = 25mA		34			34			34		V

Notes:

- These parameters, although guaranteed, are not 100% tested in production.
- Parameter measured at trip point of latch with V_{VFB} = 0.
- Gain defined as: $A = \Delta V_{COMP} / \Delta V_{ISENSE}$; $0 \leq V_{ISENSE} \leq 0.8V$
- Adjust V_{CC} above the start threshold before setting at 15V.

Block Diagram

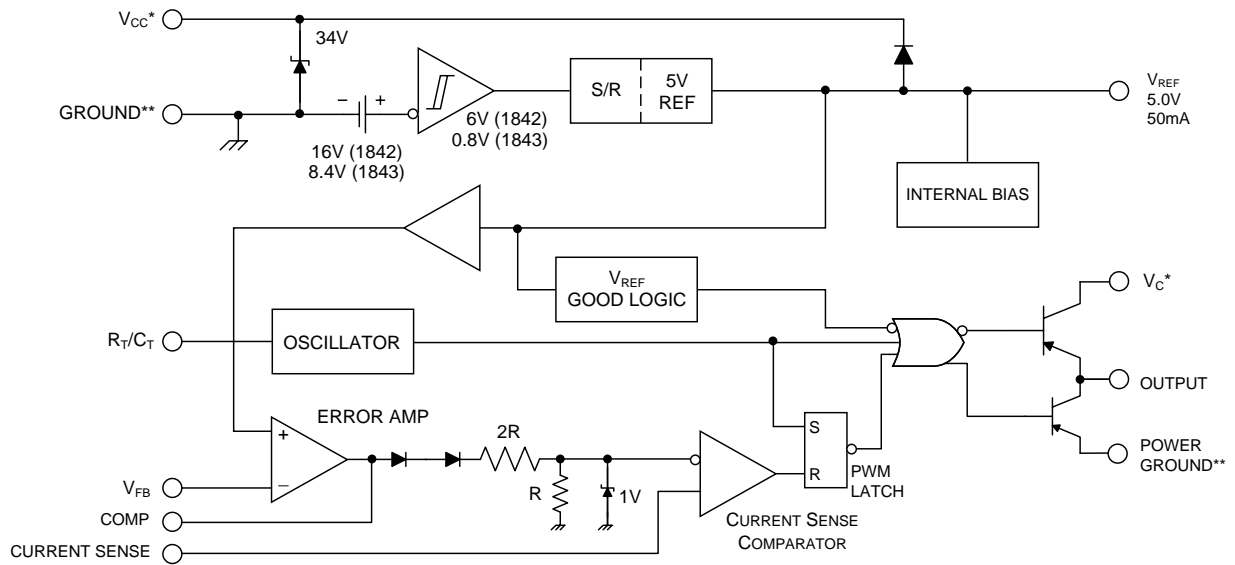

* - V_{CC} and V_C are internally connected for 8-pin packages.

** - POWER GROUND and GROUND are internally connected for 8-pin packages.

Figure 2 - Block Diagram

Characteristic Curves

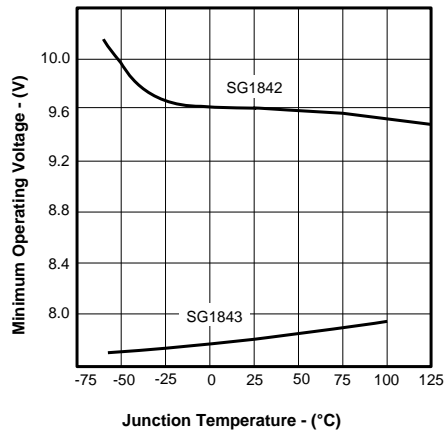

Figure 3 - Dropout Voltage vs. Temperature

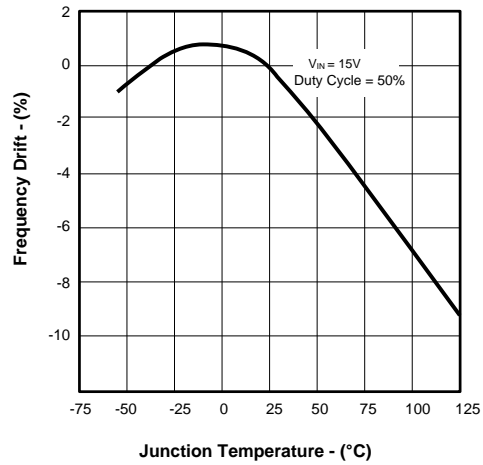

Figure 4 - Oscillator Temperature Stability

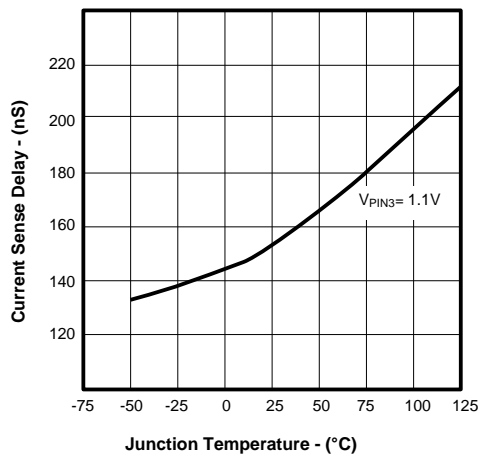

Figure 5 - Current Sense to Output Delay vs. Temperature

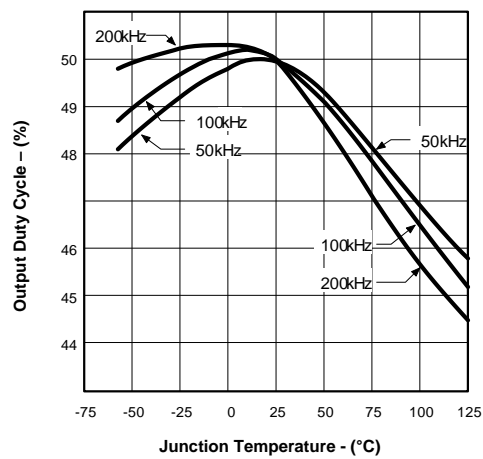

Figure 6 - Output Duty Cycle vs. Temperature

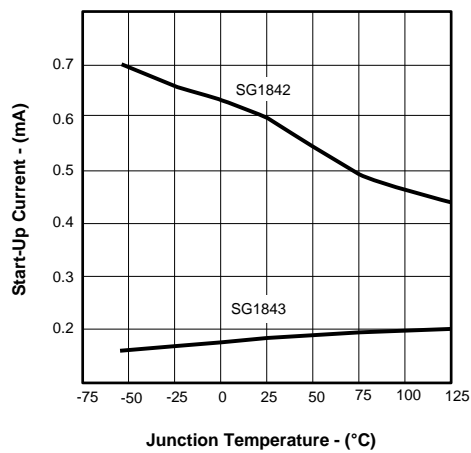

Figure 7 - Start-Up Current vs. Temperature

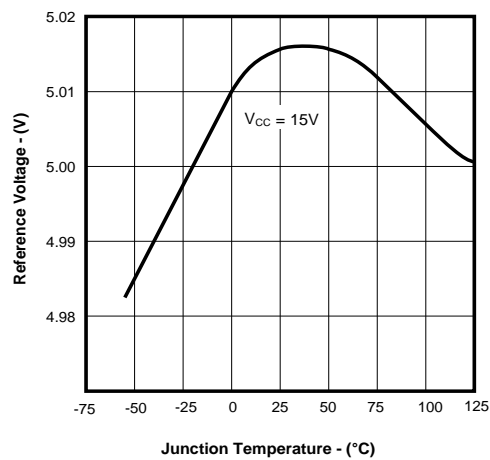

Figure 8 - Reference Voltage vs. Temperature

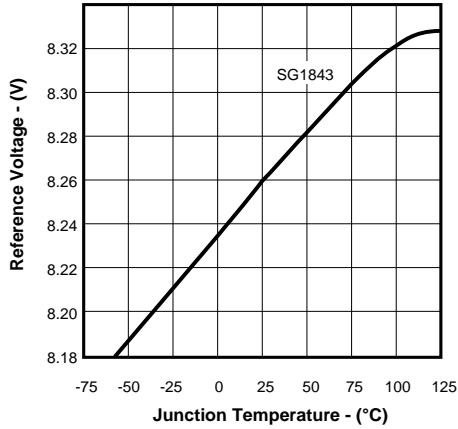

Figure 9 - Start-Up Voltage Threshold vs. Temperature

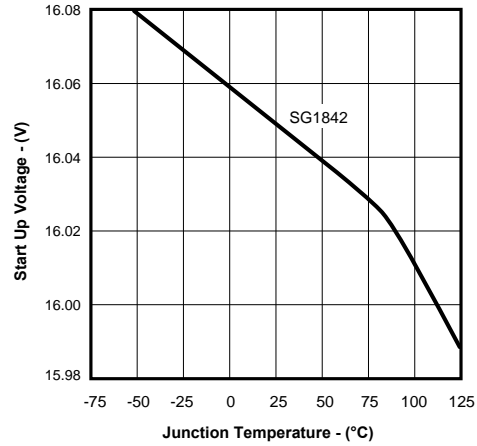

Figure 10 - Start-Up Voltage Threshold vs. Temperature

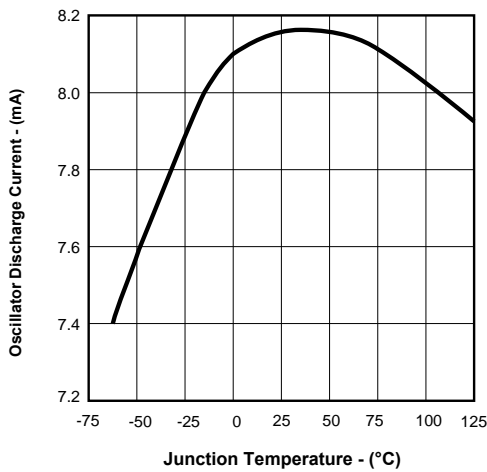

Figure 11 - Oscillator Discharge Current vs. Temperature

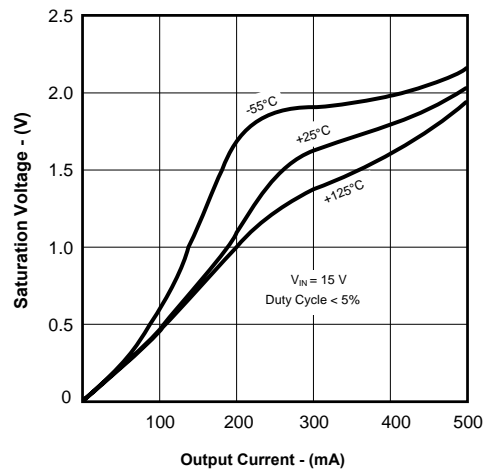

Figure 12 - Output Saturation Voltage vs. Output Current and Temperature (Sink Transistor)

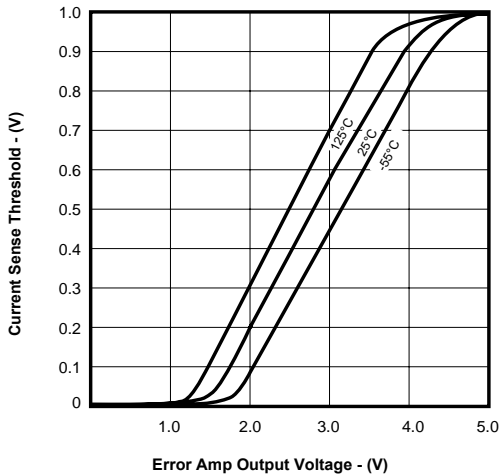

Figure 13 - Current Sense Threshold vs. Error Amplifier Output

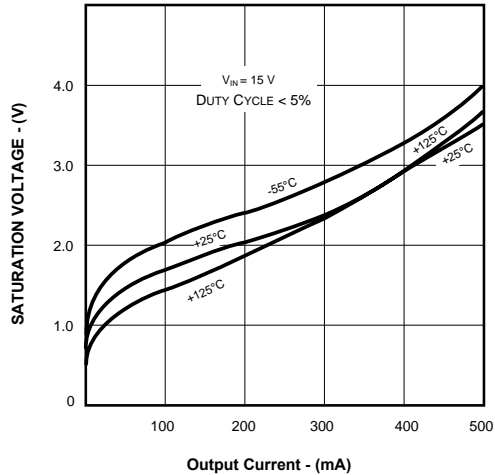

Figure 14 - Output Saturation Voltage vs. Output Current and Temperature

Application Information

The oscillator of the 1842/43 family of PWM's is designed such that many values of R_T and C_T will give the same oscillator frequency, but only one combination will yield a specific duty cycle at a given frequency.

Given:

Frequency $\equiv f$

Maximum Duty Cycle $\equiv D_m$

Calculate: $R_T = 267 \left[\frac{(1.76)^{1/D_m - 1}}{(1.76)^{(1 - D_m)/D_m - 1}} \right] (\Omega)$

where $0.3 < D_m < 0.95$

$$C_T = \frac{1.86 * D_m}{f * R_T} (\mu F)$$

For Duty-Cycles above 95% use:

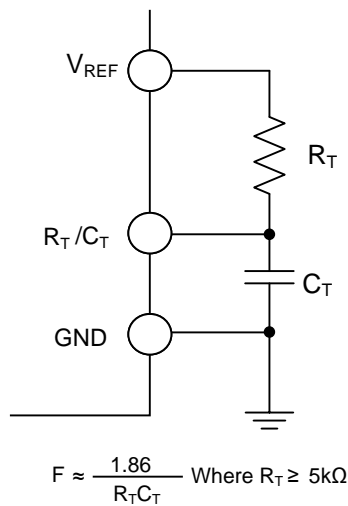

Figure 15 - Oscillator Timing Circuit

A set of formulas are given to determine the values of R_T and C_T for a given frequency and maximum duty cycle. (Note: These formulas are less accurate for smaller duty cycles or higher frequencies. This will require trimming of R_T or C_T to correct for this error.)

Example:

A Flyback power supply requires a maximum of 45% duty cycle at a switching frequency of 50 kHz. What are the values of R_T and C_T ?

Given:

$f = 50\text{kHz}$

$D_m = 0.45$

Calculate: $R_T = 267 \left[\frac{(1.76)^{\frac{1}{.45}} - 1}{(1.76)^{\frac{.55}{.45}} - 1} \right] = 674 \Omega$

$$C_T = \frac{1.86 * 0.45}{50000 * 674} = .025 (\mu\text{F})$$

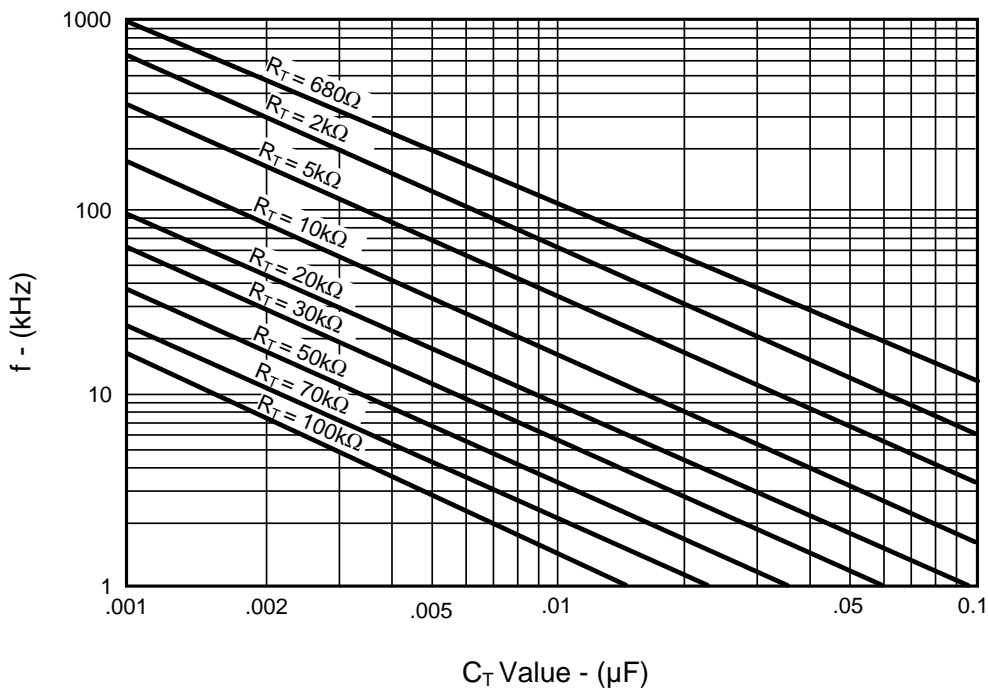

Figure 16 - Oscillator Frequency Vs. R_T For Various C_T

Typical Application Circuits

Pin numbers referenced are for 8-pin package and pin numbers in parenthesis are for 14-pin package.

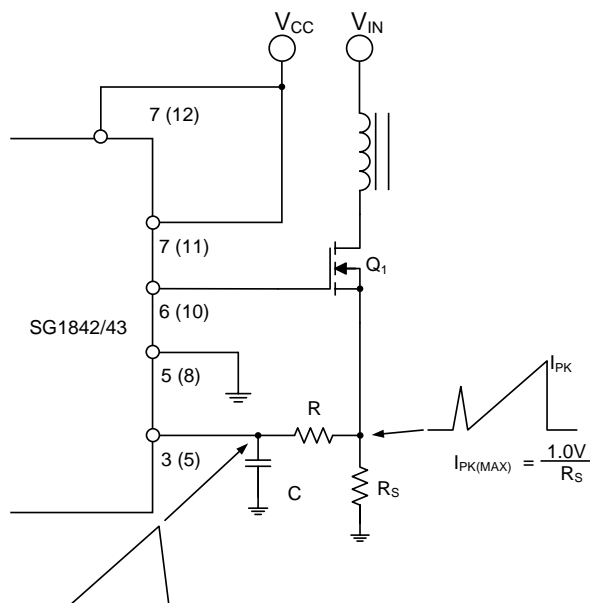

Figure 17 • Current Sense Spike Suppression

The RC low-pass filter eliminates the leading edge current spike caused by parasitic of Power MOSFET.

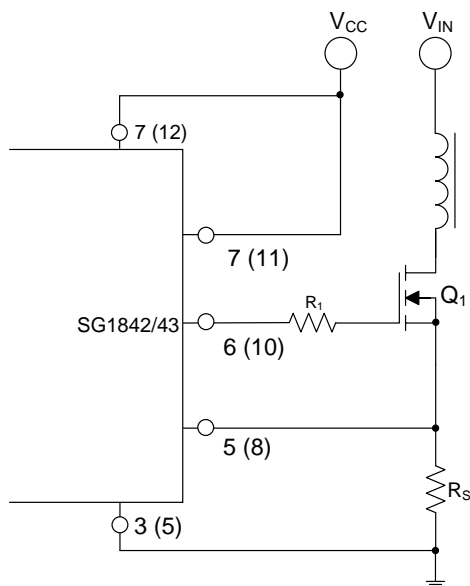

Figure 18 • MOSFET Parasitic Oscillations

A resistor (R₁) in series with the MOSFET gate reduce overshoot and ringing caused by the MOSFET input capacitance and any inductance in series with the gate drive. (Note: It is very important to have a low inductance ground path to insure correct operation of the I.C. This can be done by making the ground paths as short and as wide as possible.)

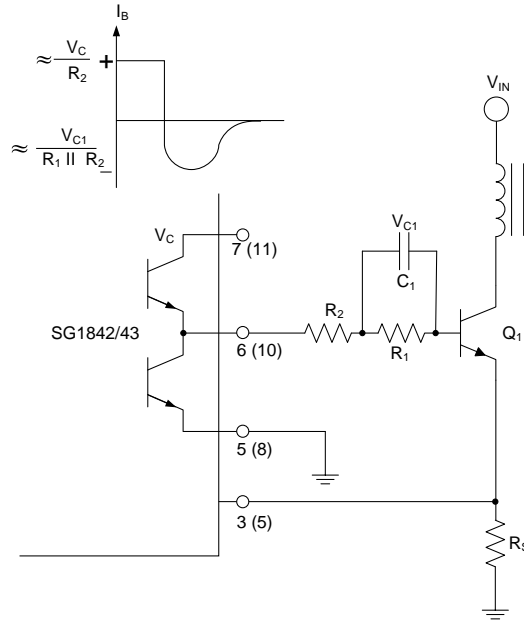

Figure 19 - Bipolar Transistor Drive

The 1842/43 output stage can provide negative base current to remove base charge of power transistor (Q_1) for faster turn off. This is accomplished by adding a capacitor (C_1) in parallel with a resistor (R_1). The resistor (R_1) is to limit the base current during turn on.

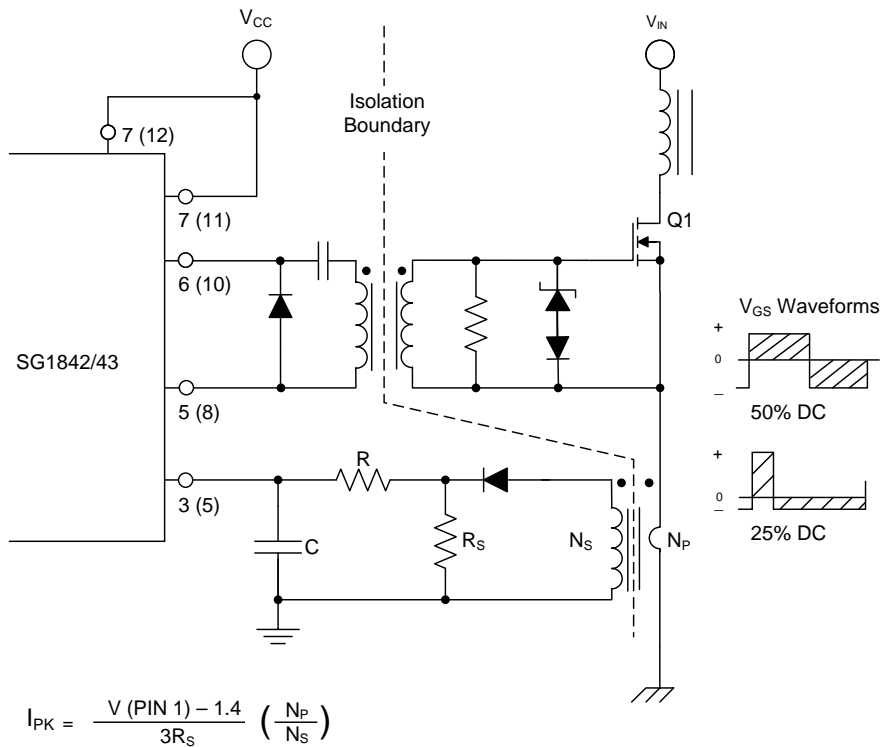

Figure 20 - Isolated MOSFET Drive

Current transformers can be used where isolation is required between PWM and Primary ground. A drive transformer is then necessary to interface the PWM output with the MOSFET.

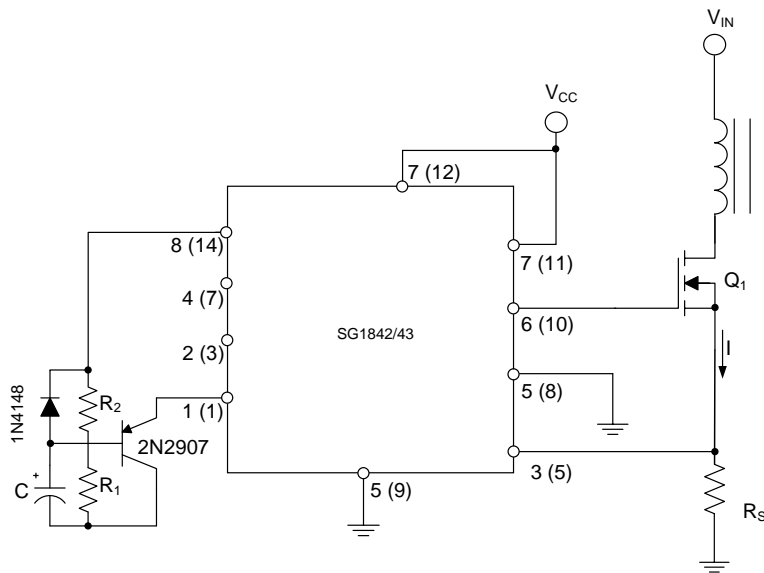

Figure 21 • Adjustable Buffered Reduction of Clamp Level with Softstart

$$I_{PK} = \frac{V_{CS}}{R_S}$$

Where, $V_{CS} = 1.67 \left(\frac{R_1}{R_1 + R_2} \right)$ and $V_{C.S.MAX} = 1V$ (Typ.)

$$t_{SOFTSTART} = -\ln \left[1 - \frac{V_{EAO} - 1.3}{5 \left(\frac{R_1}{R_1 + R_2} \right)} \right] \left(\frac{R_1 R_2}{R_1 + R_2} \right) C$$

Where, $V_{EAO} \equiv$ voltage at the Error Amp Output under minimum line and maximum load conditions
Softstart and adjustable peak current can be done with the external circuitry shown above.

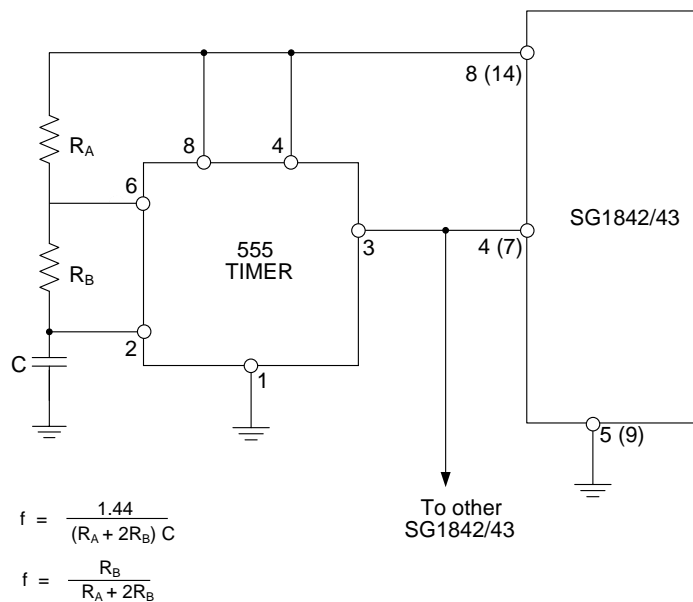

$$f = \frac{1.44}{(R_A + 2R_B) C}$$

$$f = \frac{R_B}{R_A + 2R_B}$$

Figure 22 • External Duty Cycle Clamp and Multi-Unit Synchronization

Precision duty cycle limiting as well as synchronizing several 1842/1843's is possible with the above circuitry.

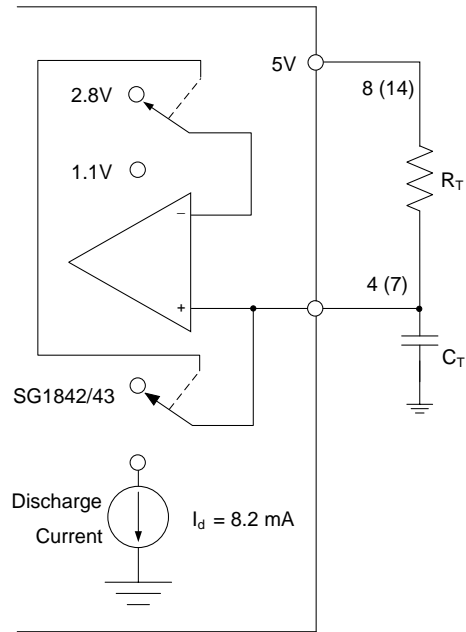

Figure 23 - Oscillator Connection

The oscillator is programmed by the values selected for the timing components R_T and C_T . Refer to application information for calculation of the component values.

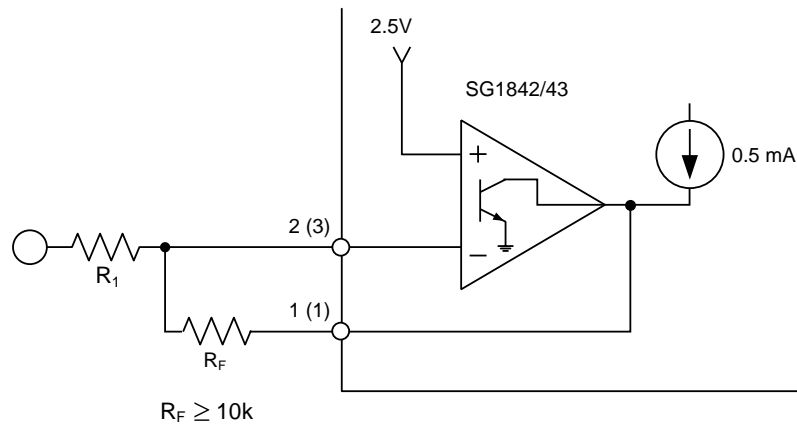

Figure 24 - Error Amplifier Connection

Error amplifier is capable of sourcing and sinking current up to 0.5mA.

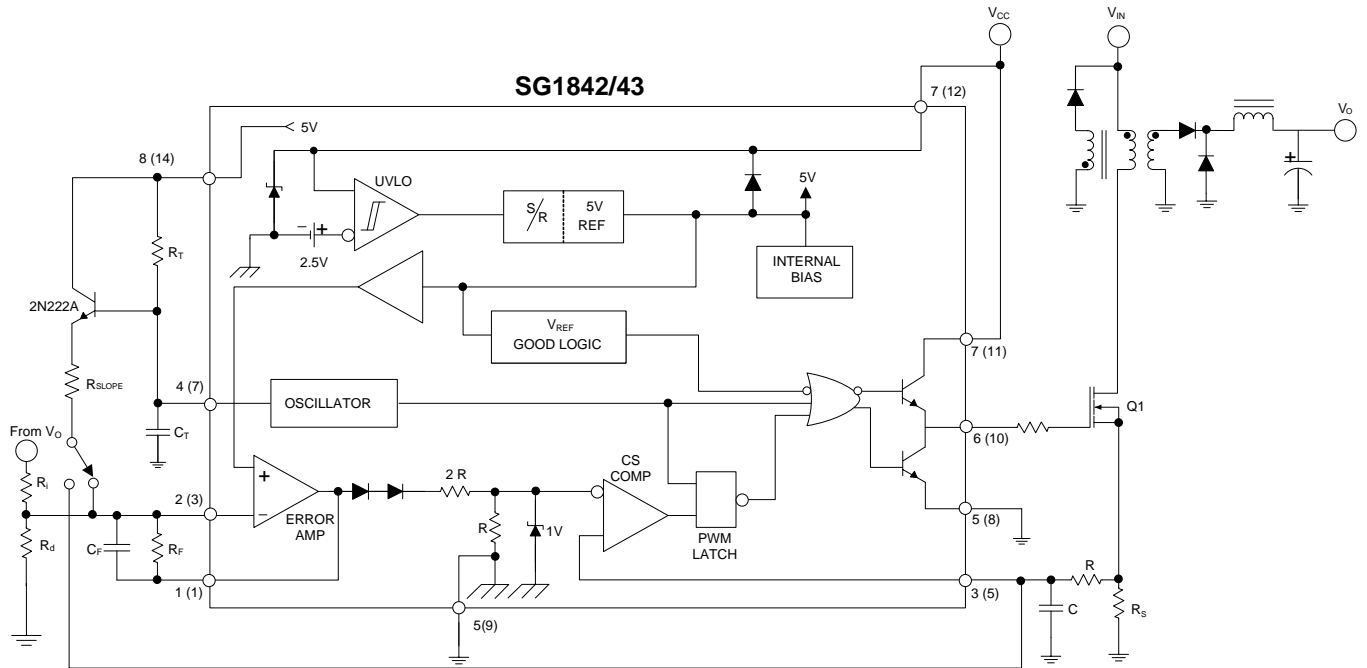

Figure 25 • Slope Compensation

Due to inherent instability of current mode converters running above 50% duty cycle, slope compensation should be added to either current sense pin or the error amplifier. Figure 25 shows a typical slope compensation technique.

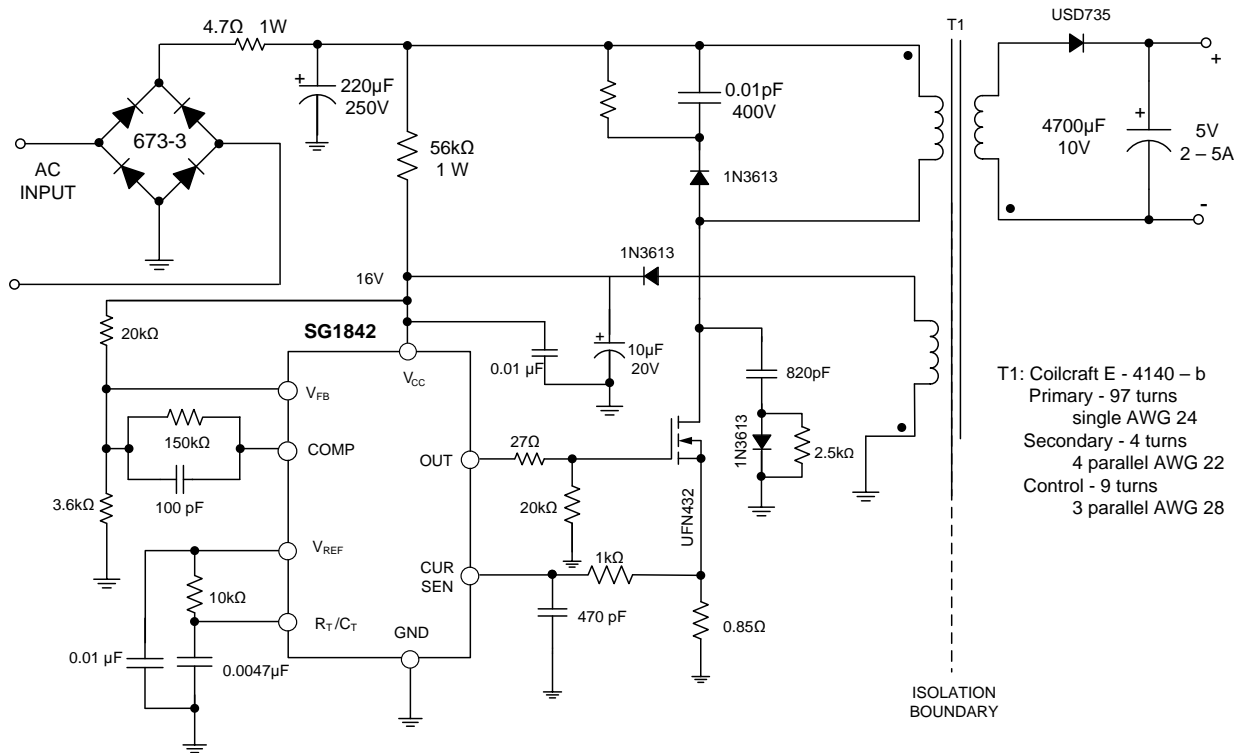

Figure 27 - Off-line Flyback Regulator

SPECIFICATIONS

- Input line voltage: 90VAC to 130VAC
- Input frequency: 50 or 60Hz
- Switching frequency: 40kHz \pm 10%
- Output power: 25W maximum
- Output voltage: 5V +5%
- Output current: 2 to 5A
- Line regulation: 0.01%/V
- Load regulation: 8%/A*
- Efficiency @ 25 Watt:
 - $V_{IN} = 90VAC$: 70%
 - $V_{IN} = 130VAC$: 65%
- Output short-circuit current: 2.5 A average

*This circuit uses a low-cost feedback scheme in which the DC voltage developed from the primary-side control winding is sensed by the SG1842 error amplifier. Load regulation is therefore dependent on the coupling between secondary and control windings, and on transformer leakage inductance.

Package Outline Dimensions

Controlling dimensions are in inches, metric equivalents are shown for general information.

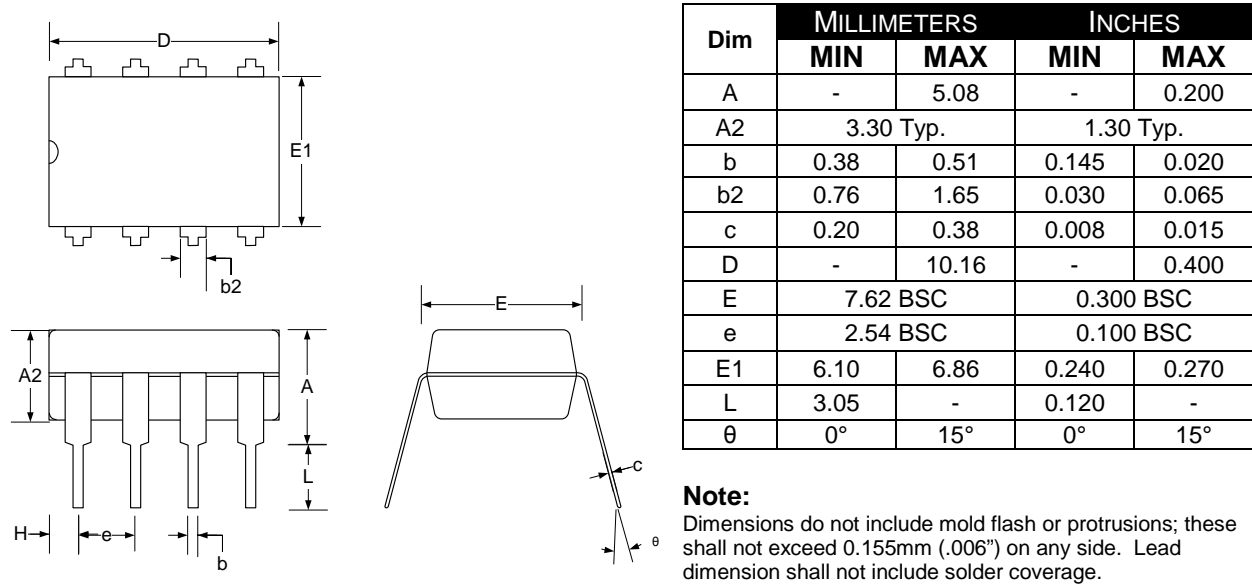

Figure 1 - M 8-Pin PDIP Package Dimensions

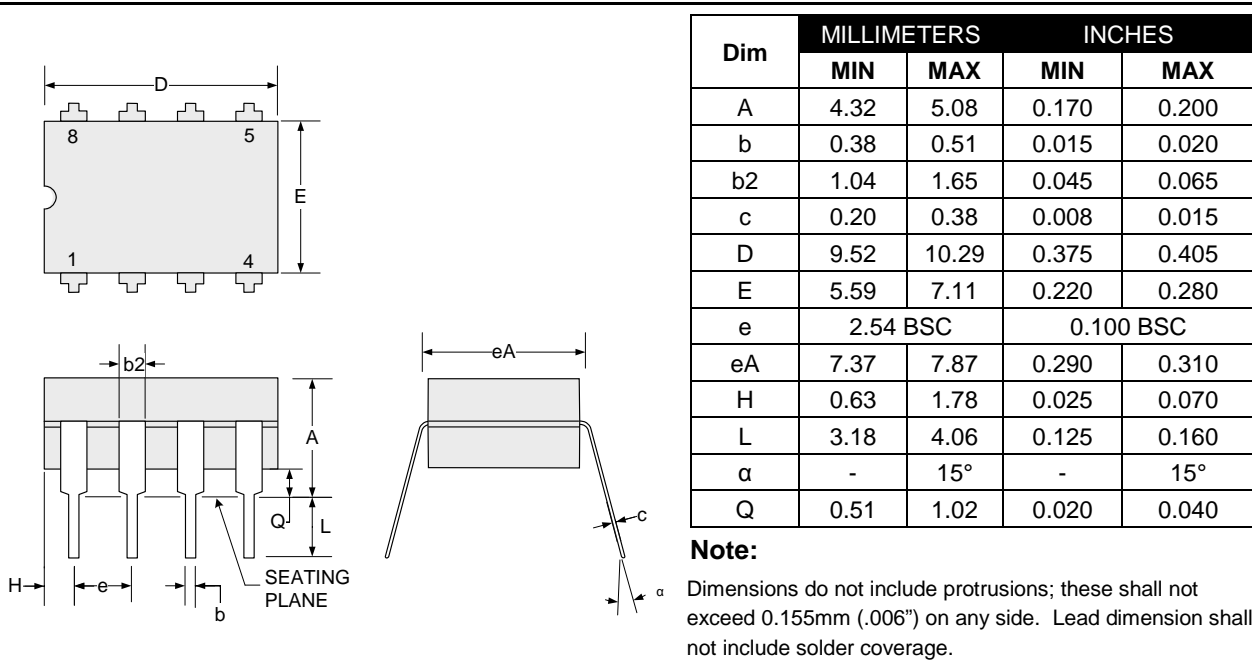
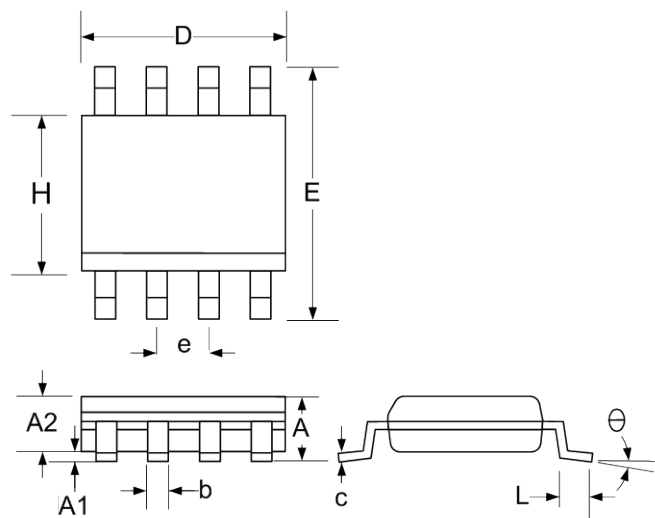

Figure 2 - Y 8-Pin CERDIP Package Dimensions

Package Outline Dimensions



Dim	MILLIMETERS		INCHES	
	MIN	MAX	MIN	MAX
A	1.35	1.75	0.053	0.069
A1	0.10	0.25	0.004	0.010
A2	1.25	1.52	0.049	0.060
b	0.33	0.51	0.013	0.020
c	0.19	0.25	0.007	0.010
D	4.83	5.21	0.189	0.205
E	5.79	6.20	0.228	0.244
e	1.27 BSC		0.050 BSC	
H	3.81	4.01	0.150	0.158
L	0.40	1.27	0.016	0.050
θ	0°	8°	0°	8°
*LC	-	.010	-	0.004

*Lead Co-planarity

Note: Dimensions do not include mold flash or protrusions; these shall not exceed 0.155mm (.006") on any side. Lead dimension shall not include solder coverage

Figure 3 - DM 8-Pin SOIC Package Dimensions

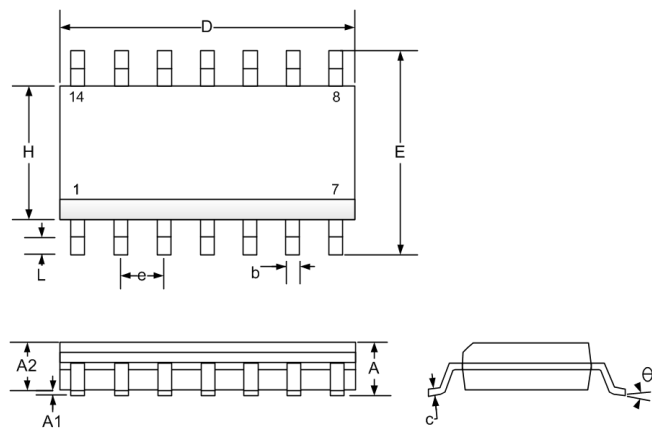

Dim	MILLIMETERS		INCHES	
	MIN	MAX	MIN	MAX
A	1.35	1.75	0.053	0.069
A1	0.10	0.25	0.004	0.010
A2	1.25	1.52	0.049	0.060
b	0.33	0.51	0.013	0.020
c	0.19	0.25	0.007	0.010
D	8.54	8.74	0.336	0.344
E	5.79	6.20	0.228	0.244
e	1.27 BSC		0.050 BSC	
H	3.81	4.01	0.150	0.158
L	0.40	1.27	0.016	0.050
θ	0°	8°	0°	8°
*LC	-	.010	-	0.004

*Lead Co-planarity

Note: Dimensions do not include mold flash or protrusions; these shall not exceed 0.155mm (.006") on any side. Lead dimension shall not include solder coverage

Figure 4 - D 14-Pin SOIC Package Dimensions

Package Outline Dimensions

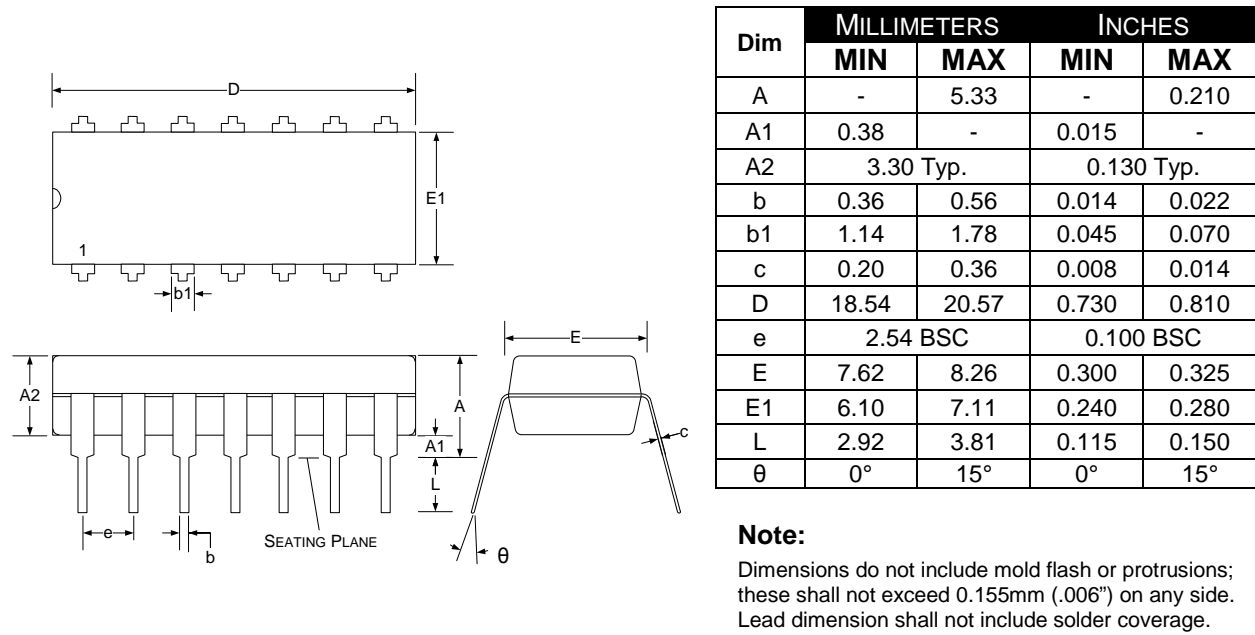

Figure 5 - N 14-Pin PDIP Package Dimensions

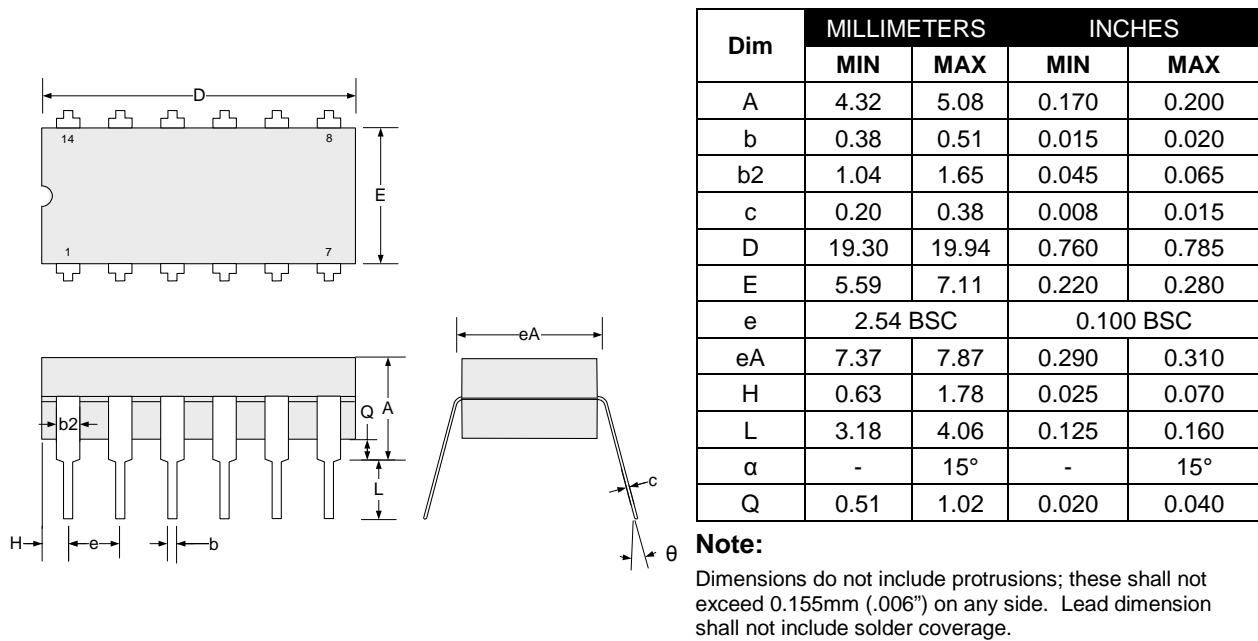
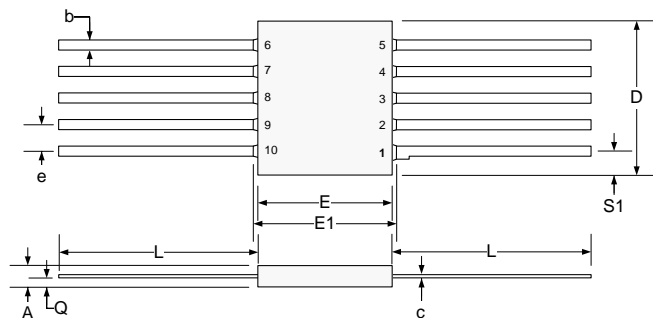

Figure 6 - J 14-Pin Cerdip Package Dimensions

Package Outline Dimensions



Dim	MILLIMETERS		INCHES	
	MIN	MAX	MIN	MAX
A	1.45	1.70	0.057	0.067
b	0.25	0.483	0.010	0.019
c	0.102	0.152	0.004	0.006
D	-	7.37	-	0.290
E	6.04	6.40	0.238	0.252
E1	-	6.91	-	0.272
e	1.27 BSC		0.050 BSC	
L	6.35	9.40	0.250	0.370
Q	0.51	1.02	0.020	0.040
S1	0.20	0.38	0.008	0.015

Notes:

1. Lead No. 1 is identified by tab on lead or dot on cover.
2. Leads are within 0.13mm (.0005") radius of the true position (TP) at maximum material condition.
3. Dimension "e" determines a zone within which all body and lead irregularities lie.

Figure 7 - F 10-Pin Ceramic Flatpack Package Dimensions

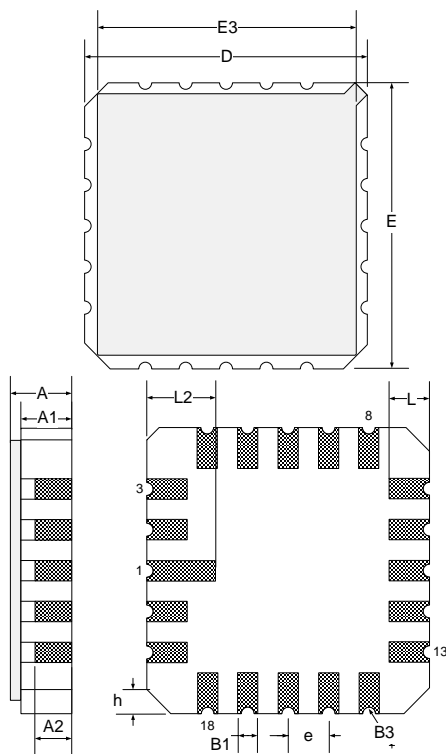

Dim	MILLIMETERS		INCHES	
	MIN	MAX	MIN	MAX
D/E	8.64	9.14	0.340	0.360
E3	-	8.128	-	0.320
e	1.270 BSC		0.050 BSC	
B1	0.635 TYP		0.025 TYP	
L	1.02	1.52	0.040	0.060
A	1.626	2.286	0.064	0.090
h	1.016 TYP		0.040 TYP	
A1	1.372	1.68	0.054	0.066
A2	-	1.168	-	0.046
L2	1.91	2.41	0.075	0.95
B3	0.203R		0.008R	

Note:

All exposed metallized area shall be gold plated 60 micro-inch minimum thickness over nickel plated unless otherwise specified in purchase order.

Figure 8 - L 20-Pin Leadless Chip Carrier Package Dimensions



Microsemi Corporate Headquarters
One Enterprise, Aliso Viejo CA 92656 USA
Within the USA: +1 (800) 713-4113
Outside the USA: +1 (949) 380-6100
Sales: +1 (949) 380-6136
Fax: +1 (949) 215-4996
E-mail: sales.support@microsemi.com

Microsemi Corporation (Nasdaq: MSCC) offers a comprehensive portfolio of semiconductor and system solutions for communications, defense and security, aerospace, and industrial markets. Products include high-performance and radiation-hardened analog mixed-signal integrated circuits, FPGAs, SoCs, and ASICs; power management products; timing and synchronization devices and precise time solutions, setting the world's standard for time; voice processing devices; RF solutions; discrete components; security technologies and scalable anti-tamper products; Power-over-Ethernet ICs and midspans; as well as custom design capabilities and services. Microsemi is headquartered in Aliso Viejo, Calif. and has approximately 3,400 employees globally. Learn more at www.microsemi.com.

© 2014 Microsemi Corporation. All rights reserved. Microsemi and the Microsemi logo are trademarks of Microsemi Corporation. All other trademarks and service marks are the property of their respective owners.