

NOTES:

1. FOR WAVESOLDERING (SOLDER BATH TEMPERATURE 265°C FOR 8 SEC. AND SOLDER PREHEAT 150°C FOR 180 SEC.)
2. IP RATING: IP 67
3. SEALED TO WITHSTAND PRESSURE UP TO 1,45 PSI FOR 30 MINUTES AFTER HIGH TEMPERATURE EXPOSURE
4. METALSHELL:
ZINC DIE CAST; min. 50µin NICKEL PLATING over COPPER
5. INSULATORS: PBT GF UL 94 V-0, BLACK
6. O-RING: SILICONE PER ASTM D2000 70 SHORE A
7. RUBBER GASKET: TPE
8. SEALING COMPOUND: EPOXY RESIN UL 94 V-0; BLACK
9. CONTACTS: COPPER ALLOY
PLATING (SEE PART NO):
 PLEASE ADD 1 for 30µin HARD GOLD over min. 50µin NICKEL
 PLEASE ADD 3 for 8µin HARD GOLD over min. 50µin NICKEL
10. METAL BRACKETS: ZINC DIE CAST;
300µin COPPER/40-120µin NICKEL/120-200µin TIN
11. WASHERS: COPPER ALLOY; 80µin NICKEL
12. HEXLOCKING SCREWS: STAINLESS STEEL
13. FIXING-PLATE: PBT GF UL 94 V-0; BLACK
14. PCB-SNAPS: COPPER ALLOY; min. 200µin TIN over 80µin NICKEL
PCB-HOLE: $\varnothing 3.1 \pm 0.1$; PCB THICKNESS 1.6mm
15. P.C.B. HOLE DRILLINGS and RECOMMENDED PANEL CUT-OUT ON SHEET 2
16. RECOMMENDED TORQUE FOR MOUNTING SCREW
35Ncm (3.1 in.LB) / max.67Ncm (6 in.LB)
17. CONNECTOR IS PART MARKED: **15-00221** CONEC ABC

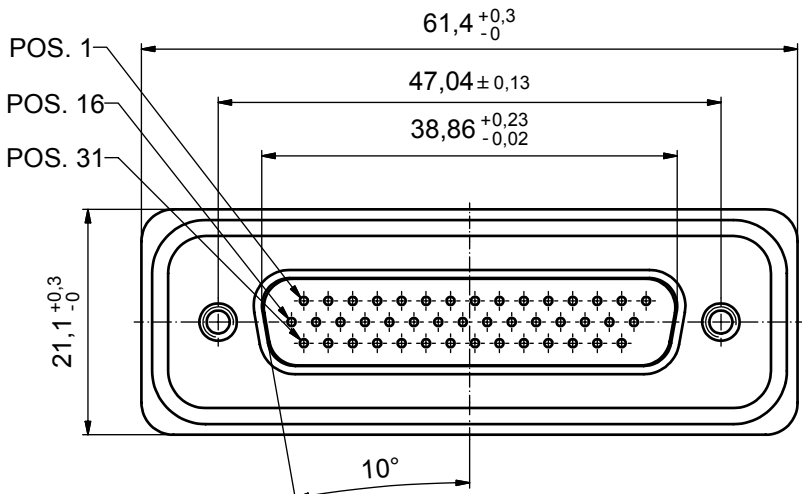

RUBBER GASKET PLACED ON TOP SURFACE OF MALE INSULATOR

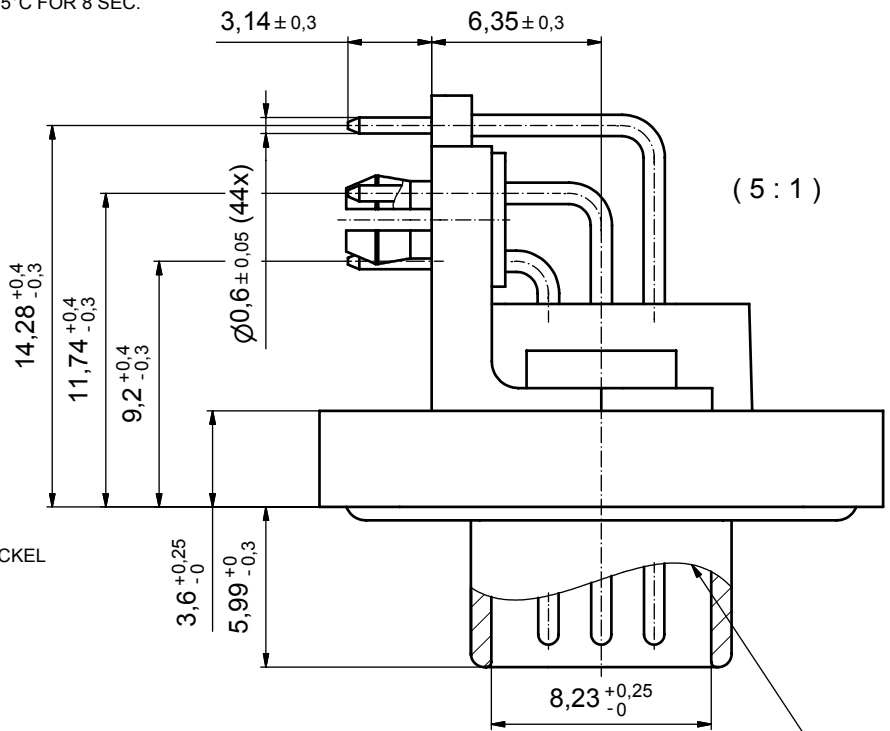
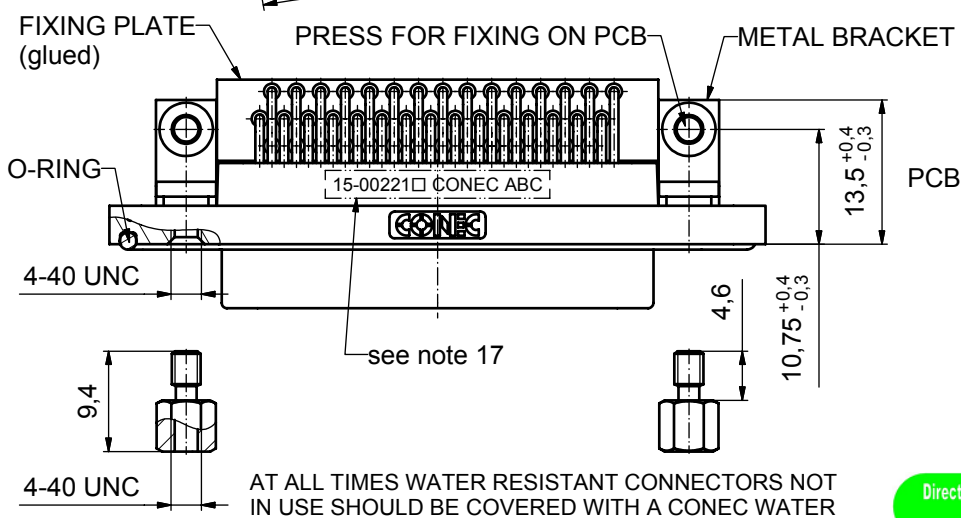
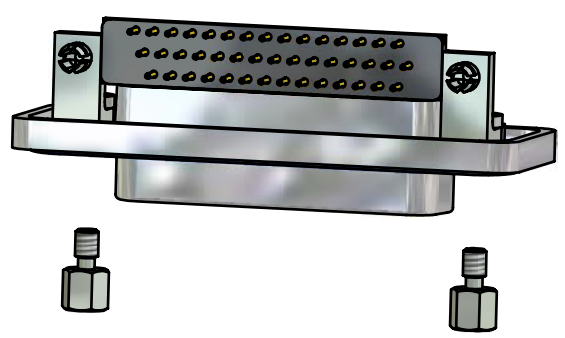

AT ALL TIMES WATER RESISTANT CONNECTORS NOT IN USE SHOULD BE COVERED WITH A CONEC WATER RESISTANT CAP OR WATER TIGHT HOOD.

Directive 2002/95/EC
„RoHS“
Compliant

APPROVAL # FREIGABE # DEBLOCAGE # AUTORIZACION # APPROVAL	
CUSTOMER APPROVAL DATE:	
NAME:	TITLE:
COMPANY NAME:	
APPROVAL # FREIGABE # DEBLOCAGE # AUTORIZACION # APPROVAL	

tolerance				dim. in mm
date				
name				
drawn 18.11.09 Schmidt				
appd. 27.11.09 Fischer				
norm				
d-old				
a	Origin			
rev.	description	date	name	

scale:	2:1 (5:1)	
material:	see notes	
title:		
D-SUB HD MALE 90°		
44pos. SOLDER PIN ANGLED		
metal bracket, fixing plate, hexlocking screw, snap		
dwg no:	Inventor 10	DIN-A3
15K1A510		sh: 1
part no:	15-00221 <input type="checkbox"/> (see note 9)	

P.C.B. HOLE DRILLINGS

(P.C.B. TOP SIDE)

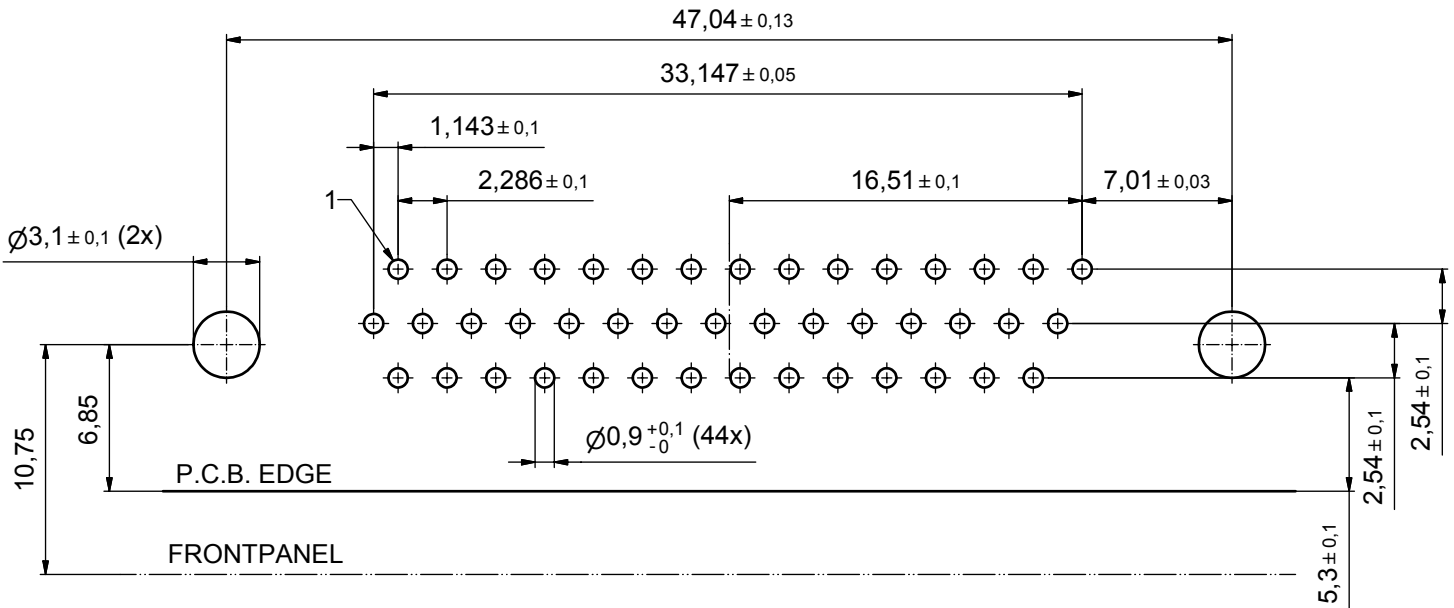

RECOMMENDED PANEL CUT-OUT

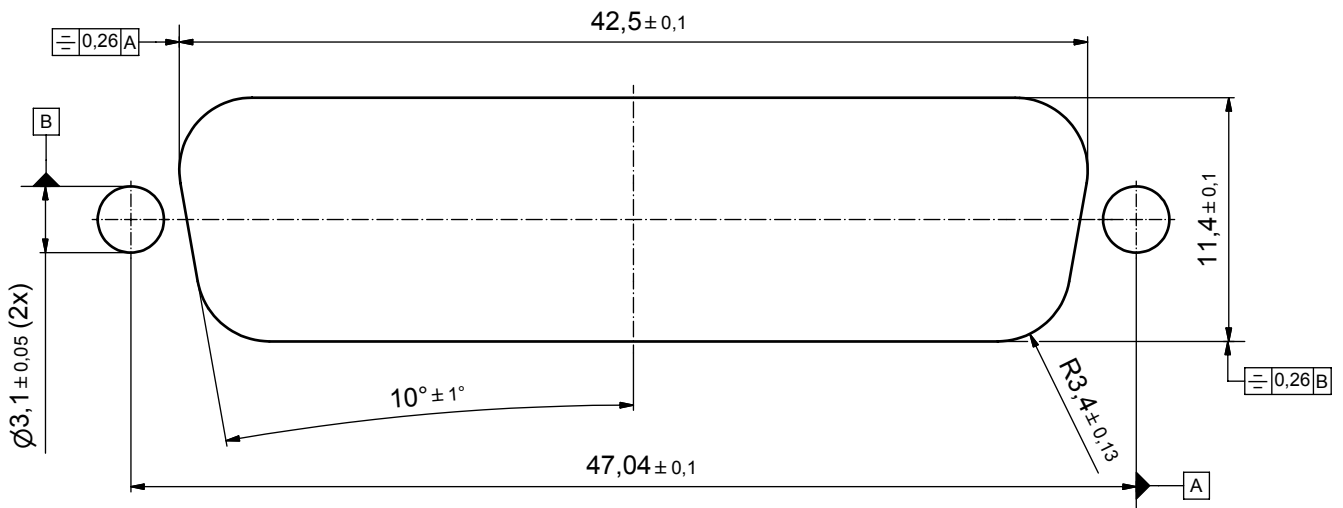

APPROVAL # FREIGABE # DEBLOCAGE # AUTORIZACION # APPROVAL	
CUSTOMER APPROVAL DATE:	
NAME:	TITLE:
COMPANY NAME:	
APPROVAL # FREIGABE # DEBLOCAGE # AUTORIZACION # APPROVAL	

THIS DRAWING MAY NOT BE COPIED OR REPRODUCED IN ANY WAY, AND MAY NOT BE PASSED ON TO A THIRD PARTY WITHOUT WRITTEN PERMISSION. OWNERSHIP AND COPYRIGHT OF CONEC GmbH			
DO NOT ALTER CAD DRAWING BY HAND			
rev.	description	date	name
a	Origin		

tolerance		dim. in mm
drawn	date	
appd.	date	name
norm		Fischer
d-old		

scale:	4:1	
material:	see sheet1	
title:	P.C.B HOLE DRILLINGS PANEL CUT-OUT D-SUB Male 44pos. HD Solder pin angled 90°	
dwg no:	Inventor 10	DIN-A3
	15K1A510	sh: 2
part no:	see sheet 1	

