

THIS DRAWING IS UNPUBLISHED. RELEASED FOR PUBLICATION .19
 © COPYRIGHT 19 BY AMP INCORPORATED. ALL RIGHTS RESERVED.

LOC	DIST	REVISIONS			
P	LTR	DESCRIPTION	DATE	DWN	APVD
AF	50	A	RELEASED PER OG1A-0057-99	17FEB1999	PF JD
		A1	REVISED PER ECR-15-017388	09DEC2015	JJ TD

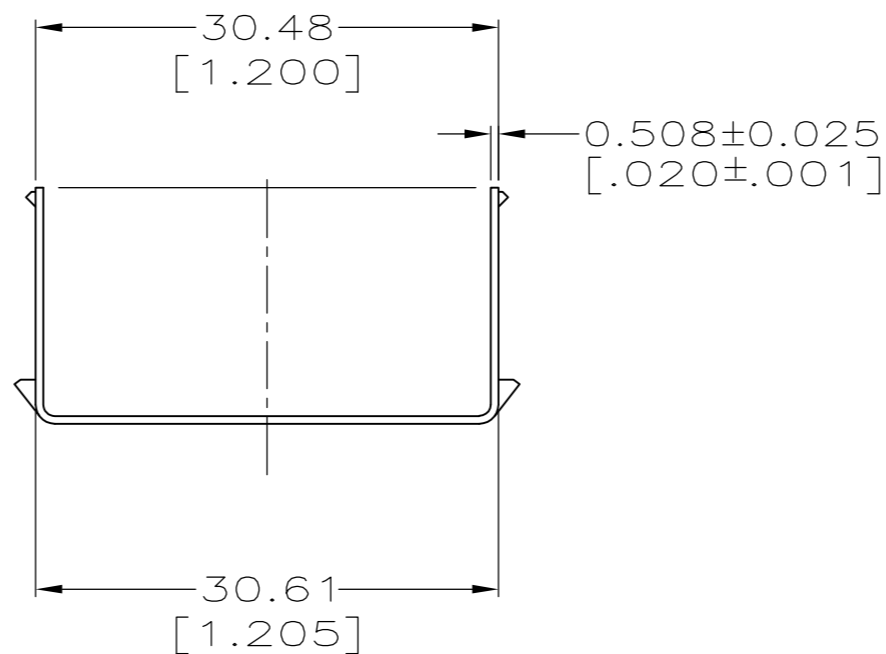

- 1 DIMENSIONS TO BE CHECKED WHEN SIDES ARE PARALLEL WITH 30.61 [1.205] DIMENSION.
- 2 30.61 [1.205] DIMENSION TO BE HELD IN THIS AREA.
- 3 30.48 [1.200] DIMENSION TO BE HELD IN THIS AREA.
- 4 FOR #10-32 MACHINE SCREW.
- 5 SUPERSEDED BY 640750-1.

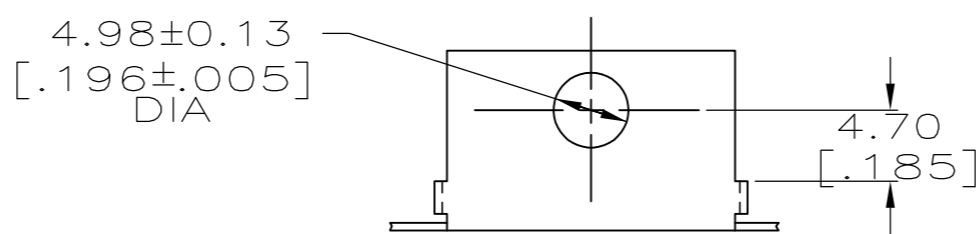
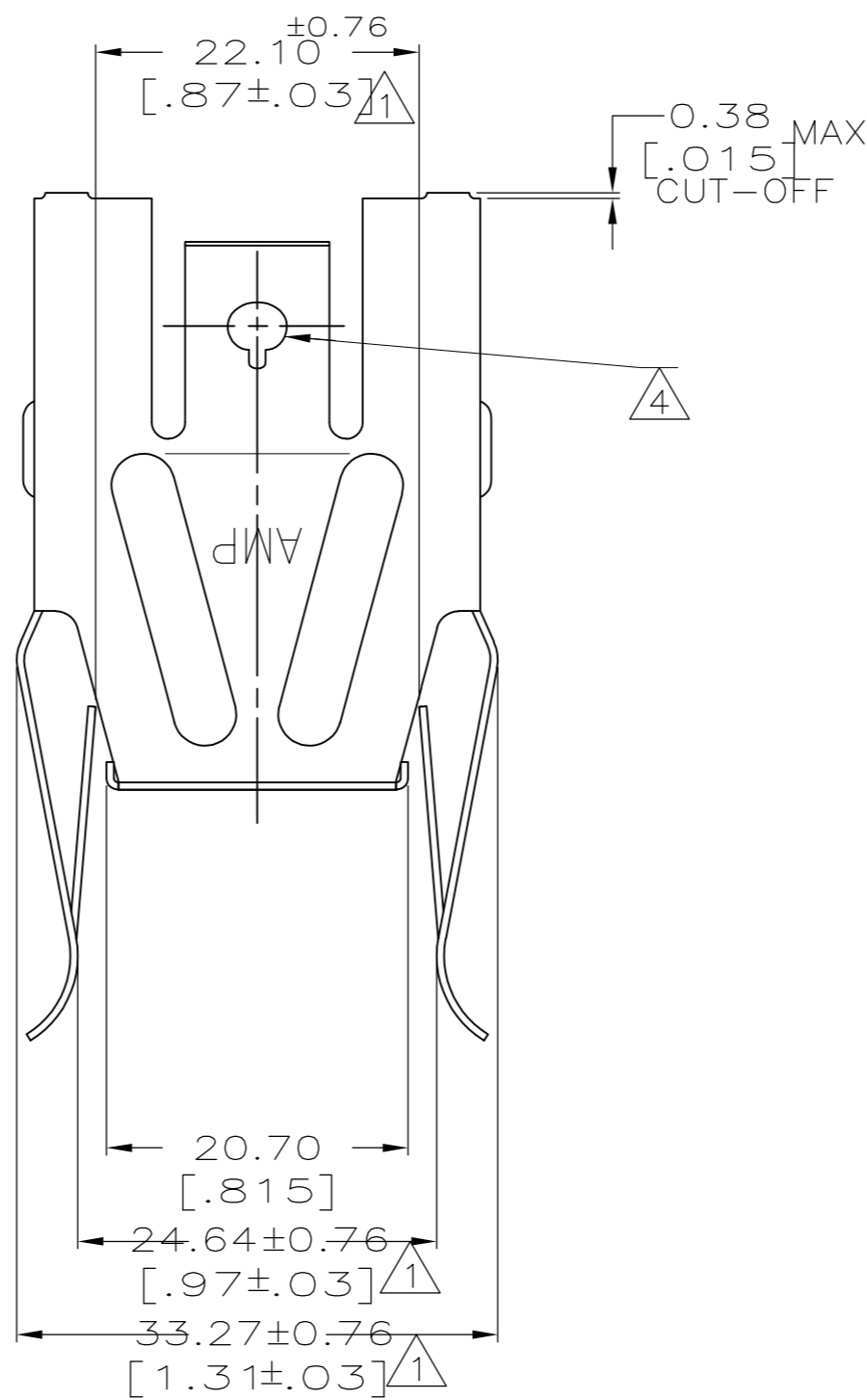
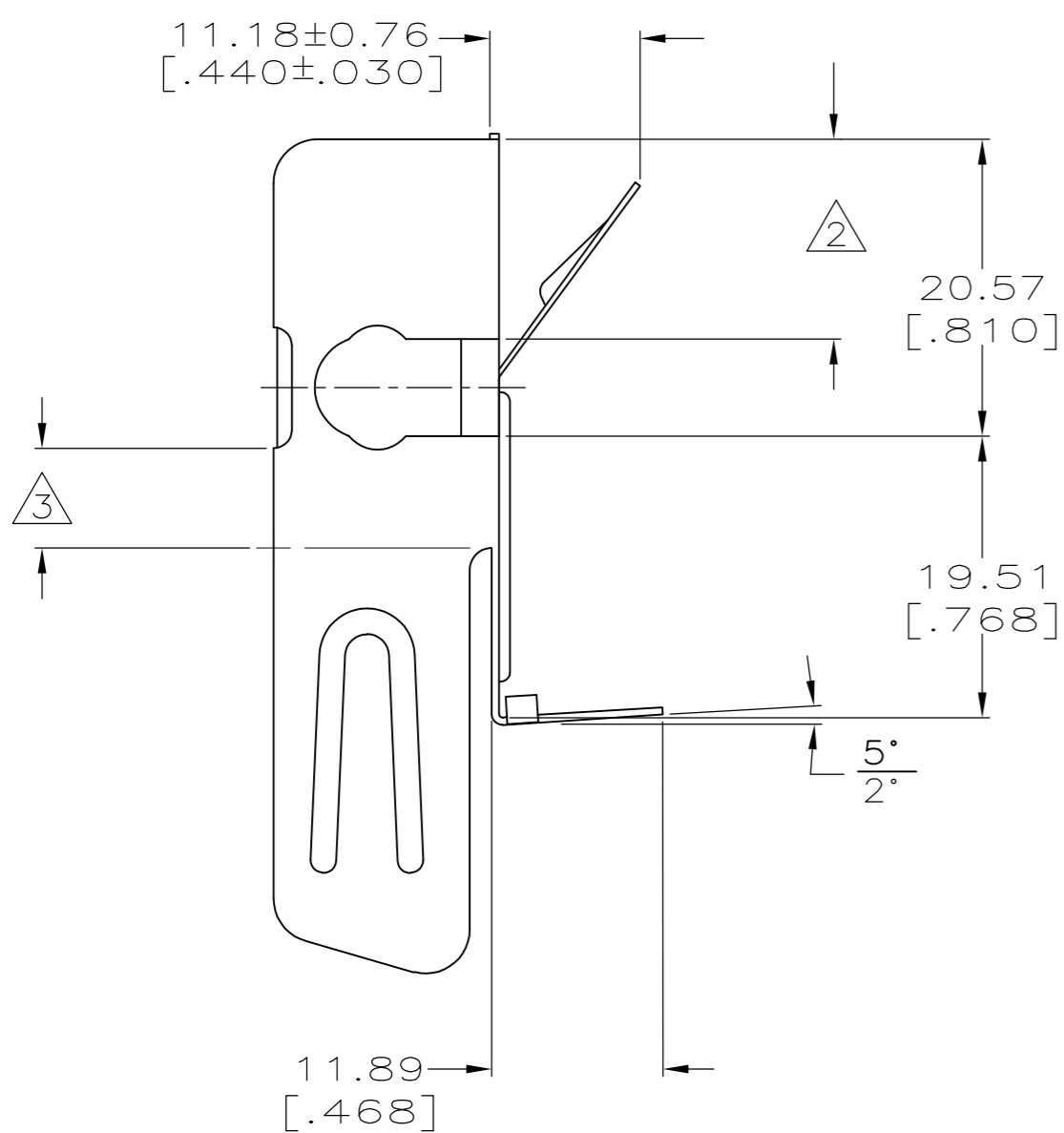

⚠ OBSOLETE -1217109-1
 PART NUMBER

THIS DRAWING IS A CONTROLLED DOCUMENT.		DWN 21NOV1998 PHILLIP M FORTNEY	AMP Incorporated Harrisburg, PA 17105-3608	
DIMENSIONS: mm[INCHES]		CHK 21NOV1998 JEFF R RUTH	NAME JEREMY DUNCAN	
TOLERANCES UNLESS OTHERWISE SPECIFIED:		APVD 21NOV1998 JEREMY DUNCAN	PRODUCT SPEC CLIP, HEAVY DUTY BURNER CONNECTOR	
0 PLC ±-		APPLICATION SPEC	SIZE	RESTRICTED TO
1 PLC ±-		WEIGHT	A2	1
2 PLC ±0.25[.010]		CUSTOMER DRAWING	CAGE CODE	SCALE
3 PLC ±-		SCALE 2:1	00779	SHEET 1 OF 1
4 PLC ±-		REV	1217109	A1
ANGLES ±-				
FINISH -				
MATERIAL 1/4 HD SST				

1217109

A