

**Impact™
Backplane Module
Installation
Press-In Tool**

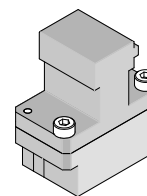

**Application Tooling
Specification Sheet**



Order No. 62201-8807

FEATURES

- Polarized tool prevents product damage
- Tool provides uniform distribution of press force across entire pin array
- May be used as a stand-alone tool or mounted in an optional holder with other Molex press-in tools

SCOPE

Products: Impact™ 85 Ohm Backplane Assembly, 170535 Series, (6-Pair by 10 Column Assemblies)
See Product List below for specific part numbers.

Product List

The following is a partial list of the product order numbers and their specifications this tool is designed to run. Updates to this list are available on www.molex.com.

170535 Series Numbers							
Guide Style	Columns	Assembly Order Number					
Open Wall	10	170535-1103	170535-1104	170535-1105	170535-1106	170535-1107	170535-1108
Dual End	10	170535-1123	170535-1124	170535-1125	170535-1126	170535-1127	170535-1128
Left End	10	170535-1113	170535-1114	170535-1115	170535-1116	170535-1117	170535-1118
Right End	10	170535-1133	170535-1134	170535-1135	170535-1136	170535-1137	170535-1138
Left Guided	10	170535-3103	170535-3104	170535-3105	170535-3106	170535-3107	170535-3108
		170535-3113	170535-3114	170535-3115	170535-3116	170535-3117	170535-3118
		170535-3123	170535-3124	170535-3125	170535-3126	170535-3127	170535-3128
		170535-3133	170535-3134	170535-3135	170535-3136	170535-3137	170535-3138
		170535-3143	170535-3144	170535-3145	170535-3146	170535-3147	170535-3148
		170535-3153	170535-3154	170535-3155	170535-3156	170535-3157	170535-3158
		170535-3163	170535-3164	170535-3165	170535-3166	170535-3167	170535-3168
		170535-3173	170535-3174	170535-3175	170535-3176	170535-3177	170535-3178
		170535-3183	170535-3184	170535-3185	170535-3186	170535-3187	170535-3188
		170535-7103	170535-7104	170535-7105	170535-7106	170535-7107	170535-7108
		170535-7113	170535-7114	170535-7115	170535-7116	170535-7117	170535-7118
		170535-7123	170535-7124	170535-7125	170535-7126	170535-7127	170535-7128
		170535-7133	170535-7134	170535-7135	170535-7136	170535-7137	170535-7138
		170535-7143	170535-7144	170535-7145	170535-7146	170535-7147	170535-7148
		170535-7153	170535-7154	170535-7155	170535-7156	170535-7157	170535-7158
		170535-7163	170535-7164	170535-7165	170535-7166	170535-7167	170535-7168
		170535-7173	170535-7174	170535-7175	170535-7176	170535-7177	170535-7178
		170535-7183	170535-7184	170535-7185	170535-7186	170535-7187	170535-7188
Right Guided	10	170535-5103	170535-5104	170535-5105	170535-5106	170535-5107	170535-5108
		170535-5113	170535-5114	170535-5115	170535-5116	170535-5117	170535-5118
		170535-5123	170535-5124	170535-5125	170535-5126	170535-5127	170535-5128
		170535-5133	170535-5134	170535-5135	170535-5136	170535-5137	170535-5138
		170535-5143	170535-5144	170535-5145	170535-5146	170535-5147	170535-5148

		170535 Series Numbers					
Guide Style	Columns	Assembly Order Number					
Right Guided	10	170535-5153	170535-5154	170535-5155	170535-5156	170535-5157	170535-5158
		170535-5163	170535-5164	170535-5165	170535-5166	170535-5167	170535-5168
		170535-5173	170535-5174	170535-5175	170535-5176	170535-5177	170535-5178
		170535-5183	170535-5184	170535-5185	170535-5186	170535-5187	170535-5188
		170535-9103	170535-9104	170535-9105	170535-9106	170535-9107	170535-9108
		170535-9113	170535-9114	170535-9115	170535-9116	170535-9117	170535-9118
		170535-9123	170535-9124	170535-9125	170535-9126	170535-9127	170535-9128
		170535-9133	170535-9134	170535-9135	170535-9136	170535-9137	170535-9138
		170535-9143	170535-9144	170535-9145	170535-9146	170535-9147	170535-9148
		170535-9153	170535-9154	170535-9155	170535-9156	170535-9157	170535-9158
		170535-9163	170535-9164	170535-9165	170535-9166	170535-9167	170535-9168
		170535-9173	170535-9174	170535-9175	170535-9176	170535-9177	170535-9178
		170535-9183	170535-9184	170535-9185	170535-9186	170535-9187	170535-9188

Tool Setup

Depending on the number of connectors to be installed and/or the press used, this tool can be used alone or with a group of press-in tools, mounted in a 62201-95XX rail (ordered separately). See Figure 1.

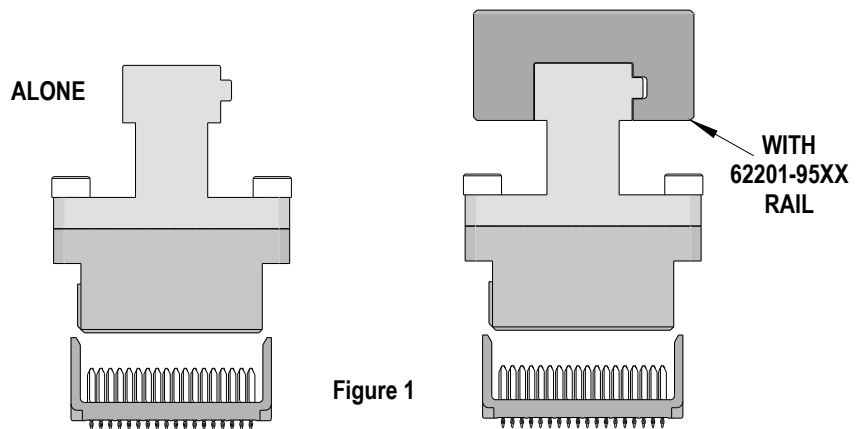

Tool Installation

The 62201-95XX rail is available in a variety of lengths to accommodate multiple press-in tools.

Rail Part Number	Rail Overall Length
62201-9501	24mm (0.94 in)
62201-9502	72mm (2.83 in)
62201-9503	156mm (6.14 in)
62201-9504	216mm (8.50 in)
62201-9509	254mm (10.0 in)
62201-9511	305mm (12.0 in)

Reference: This Press-In Tool is 18.9mm (0.74 in.) long.

Printed Circuit Board (PCB) Support

The Impact™ connectors require up to 3.6kg (8 lb) of force per pin to press into the PCB. To prevent excessive PCB flexure and/or damage to the PCB, a support plate is strongly recommended directly beneath the connector hole pattern.

Due to the custom nature of every application, Molex does not offer any PCB support plate. The customer must furnish their own support plate.

When creating the PCB support plate, remember to allow clearance for the connector pins as they pass through the PCB thickness.

Press Equipment Recommendations

Many types of presses can be used to install Impact™ connectors, but to assure consistent connector installation Molex recommends the following press criteria:

1. The capability to detect force variations as low as 4.5kg (10 lb) during the press-in cycle; excessive force measurements should stop the press-in cycle.
2. The rate of pressing can be regulated as low as 0.13mm (0.005 in) per second.
3. Press stroke control to within 0.25mm (0.010 in).
4. Total press stroke must be at least 19mm (0.75 in).
5. For statistical purposes, automatic collection of force and distance data.

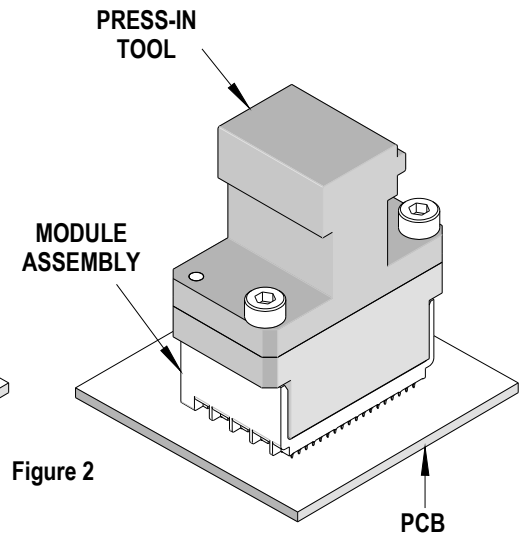
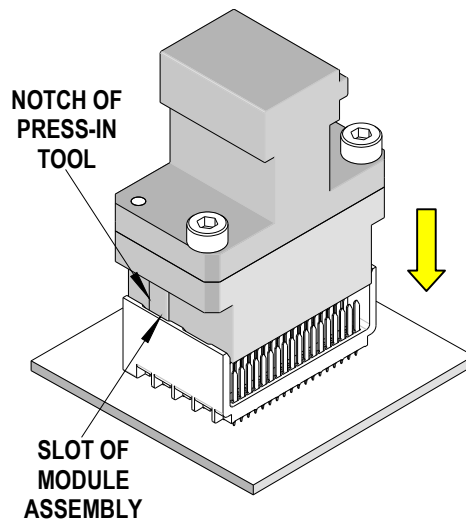

Figure 2

Tool Operation

1. Insert by hand the backplane signal module assembly (s) carefully into the PCB hole pattern. Make sure the connector(s) are oriented properly by confirming the location of the #1 circuit notch with respect to the PCB layout.
2. Insert the Press-In Tool making sure that the notch in this tool is inserted into the slot on top of the connector housing of the backplane signal module assembly. See Figure 2.
3. Using the application tool and an appropriate press, seat the header assembly until there is less than 0.10mm (.004 in) clearance between the bottom of the plastic housing and the surface of the PCB. See Figure 3.

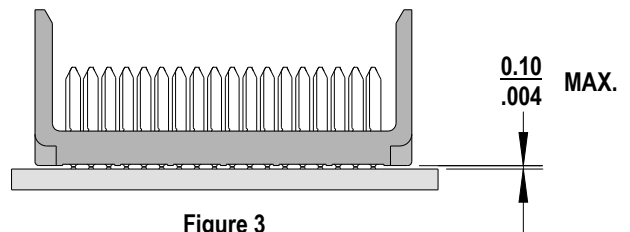

Figure 3

There should be no broken stand-offs along the perimeter of the part (an indication of over-pressing).

CAUTION: To prevent injury, never operate any press without the guards in place. Refer to the press manufacturer's instruction manual.

CAUTION: Molex application tooling specifications are valid only when used with Molex connectors and tooling.

Contact Information

For more information on Molex application tooling please contact Molex at 1-800-786-6539.

<http://www.molex.com>