

# Customer Information Sheet

DRAWING No.: H1390-XX

SHEET 2 OF 2

IF IN DOUBT - ASK

©

NOT TO SCALE

THIRD ANGLE PROJECTION

ALL DIMENSIONS IN mm

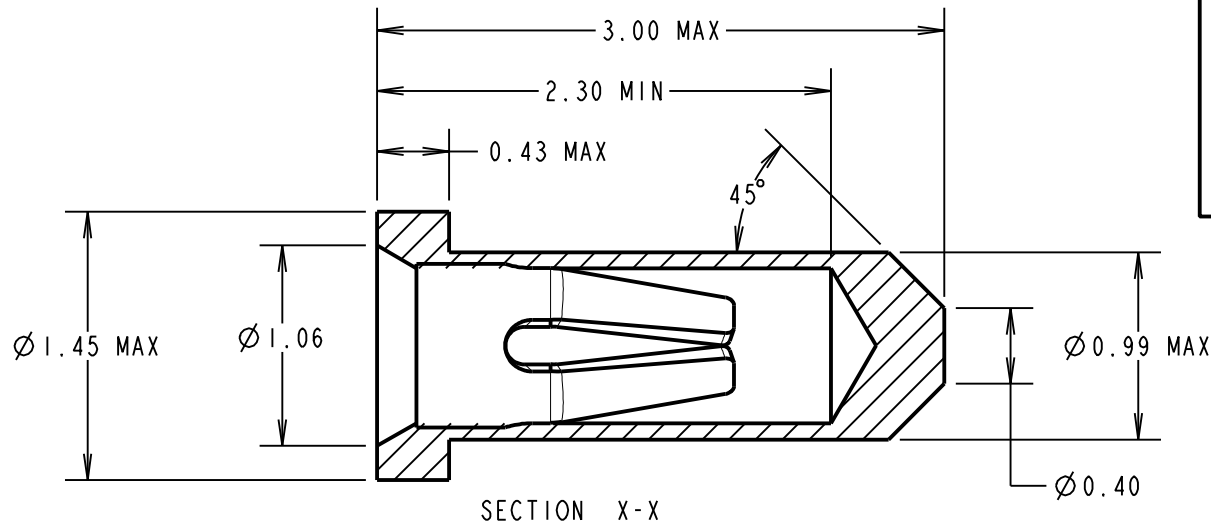

ORDER CODE:

**H3190-XX**

FINISH:

- 01 - GOLD CLIP, TIN SHELL
- 05 - GOLD CLIP, GOLD SHELL
- 46 - 100% TIN CLIP, 100% TIN SHELL

**SPECIFICATION:**

**MATERIAL:**

CONTACT SHELL = BRASS  
CONTACT CLIP = BERYLLIUM COPPER

**FINISH:**

- 01 = 4μ TIN SHELL, 0.15μ GOLD CLIP
- 05 = 0.1μ GOLD SHELL, 0.15μ GOLD CLIP
- 46 = 4μ 100% TIN SHELL, 2.4μ 100% TIN CLIP

**ELECTRICAL:**

CURRENT RATING AT 25°C = 2A MAX  
CURRENT RATING AT 85°C = 1.75A MAX  
CONTACT RESISTANCE = 25 MILLIOHMS MAX

**MECHANICAL:**

INSERTION FORCE (∅0.5mm GAUGE) = 6N MAX, 2N MIN  
WITHDRAWAL FORCE (∅0.5mm GAUGE) = 1.5N MAX, 0.5N MIN

**DURABILITY:**

- 01, 05 FINISH = 500 OPERATIONS
- 46 FINISH = 50 OPERATIONS

**ENVIRONMENTAL:**

OPERATING TEMPERATURE = -55°C TO +125°C  
FOR COMPLETE SPECIFICATION, SEE COMPONENT SPECIFICATION C006XX (LATEST ISSUE)

**NOTES:**

1. RECOMMENDED PIN LENGTH = 2.30mm MAX.
2. RECOMMENDED MOUNTING HOLE SIZE = ∅1.10-1.00mm.
3. RECOMMENDED PIN SIZE = ∅0.46-0.51mm.
4. CONTACT DEPTH = 2.30mm MAX

MSP	7	04.11.14	12661
NAME	ISS.	DATE	C/NOTE
APPROVED: M.PERREN			
CHECKED: M.PLESTED			
DRAWN: M.PERREN			
CUSTOMER REF.:			
ASSEMBLY DRG:			

**HARWIN**

www.harwin.com  
technical@harwin.com

THIS DRAWING AND ANY INFORMATION OR DESCRIPTIVE MATTER SET OUT HEREON ARE CONFIDENTIAL AND COPYRIGHT PROPERTY OF THE HARWIN GROUP AND MUST NOT BE DISCLOSED, LOANED, COPIED OR USED FOR MANUFACTURING, TENDERING OR FOR ANY OTHER PURPOSE WITHOUT THEIR WRITTEN PERMISSION.

**TOLERANCES**

- X. = ±1mm
- X.X = ±0.25mm
- X.XX = ±0.10mm
- X.XXX = ±0.01mm

ANGLES = ±5°  
UNLESS STATED

**MATERIAL:**

SEE ABOVE

FINISH: SEE ABOVE

S/AREA:

mm<sup>2</sup>

**TITLE:**

SUB-MINATURE  
SOCKET ASSEMBLY

DRAWING NUMBER:

**H3190-XX**

SHT  
1  
OF  
2