

©1972 BY AMP INCORPORATED. ALL RIGHTS RESERVED. AMP PRODUCTS COVERED BY PATENTS AND/OR PATENTS PENDING.

THIS PRODUCT DESIGNED AND BUILT BY AMP INCORPORATED. NO LICENSE TO USE THAT DESIGN IN MANUFACTURE, OR TO USE ANY ISSUED OR PENDING PATENTS WHICH ARE INVOLVED, IS IMPLIED.

REVISIONS				
ZONE	LTR	DESCRIPTION	DATE	APPROVED
	A	1.19 DIA WAS 1.12 & RET. RING WAS RUBBER; ADDED COLOR CODE TO KEYWAYS	3/14/72	M.S.
	B	ADDED -2 ADDED NOTE 3 & 4	1/10/74	M.S.
	C	ADDED -3	2-26-76	M.S.
	D	ADDED -4, -5, -6	6-30-77	M.S.
	E	OBSOLETE -3, -6	ECN 53615 11-5-86	R.S.
	F	REV PER 0414-120-04	10-04	CT

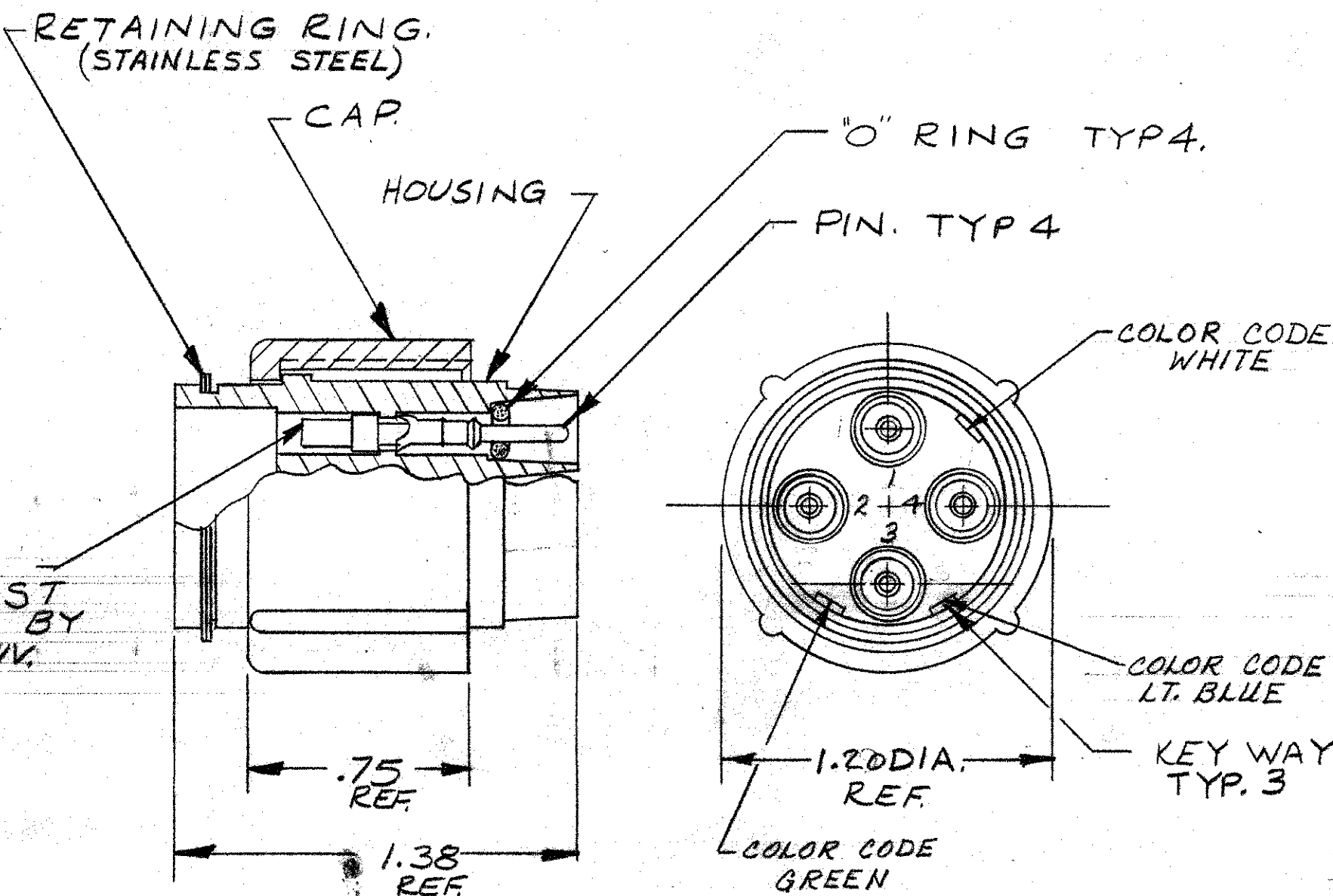

- NOTE:
- MARKING, WHITE.
  - #16 GA. PINS. GOLD PLATED PER MIL-G-45204, TYPE II, .00005 THK. MIN.
  - PLUG & PINS SHIPPED SEPARATELY.
  - TYPE II PINS TO ACCEPT (1) 22 AWG, (1) 20 AWG, OR (1) 24 AWG STRANDED WIRE
  - TYPE II PINS TO ACCEPT (1) 16 AWG, OR 18 AWG STRANDED WIRE
  - TO REMOVE PINS USE EXTRACTION TOOL NO. 860751-1
  - TYPE II PINS TO ACCEPT ONE (1) 14 AWG STRANDED WIRE.

AMP P/N	WIRE SIZE RANGE	HAND TOOL	COLOR CODING
860265-1	20, 22, 24	45099	YES
-2	16, 18	45098	YES
-3	14	45098	YES
-4	20, 22, 24	45099	NO
-5	16, 18	45098	NO
860265-6	14	45098	NO

QTY REQD	QTY REQD	ITEM NO.	DWG SIZE	PART OR IDENTIFYING NO.	NOMENCLATURE OR DESCRIPTION	SYMBOL
					PARTS LIST	
UNLESS OTHERWISE SPECIFIED: DIMENSIONS ARE IN INCHES TOLERANCES .00 ±      ANGLES = .000 ±      J				CONTRACT NO. 3-25-72	AMP INCORPORATED CAPITRON DIVISION ELIZABETHTOWN, PENNSYLVANIA	
MATERIAL: MOLDED PLASTIC				DR C. Stone	NAME PLUG ASS'Y A PIN.	
FINISH: BLACK.				CHK M. Andra 3/25/72	EGH	
NEXT ASSY	FINAL ASSY	NEXT ASSY	USED ON	DSGN APPD	SIZE C	CODE IDENT NO. 00779
				OTHER APPD	NUMBER 860265	REV F
APPLICATION				SCALE NONE	WT	SHEET 1 OF 1