

MOD		LOC		DIST		REVISIONS				
ZONE	LTR	DESCRIPTION	DATE	APPD						
4	BD	39	P	F	W	ADDED -7 PER NPR 4680 AND REDRAWN ON CAD	04/06/93	-		
					W1	REVISION PER ECO-10-000030	07/12/09	AEG		

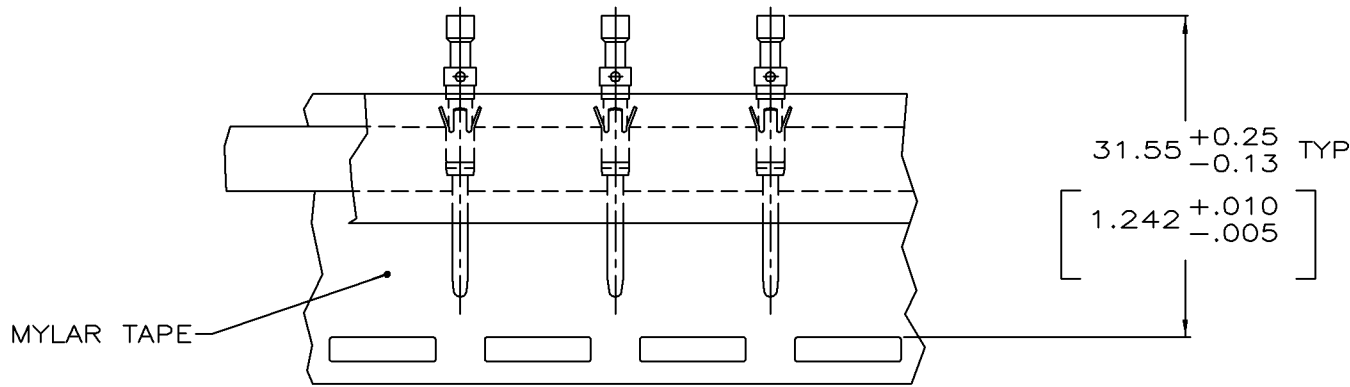
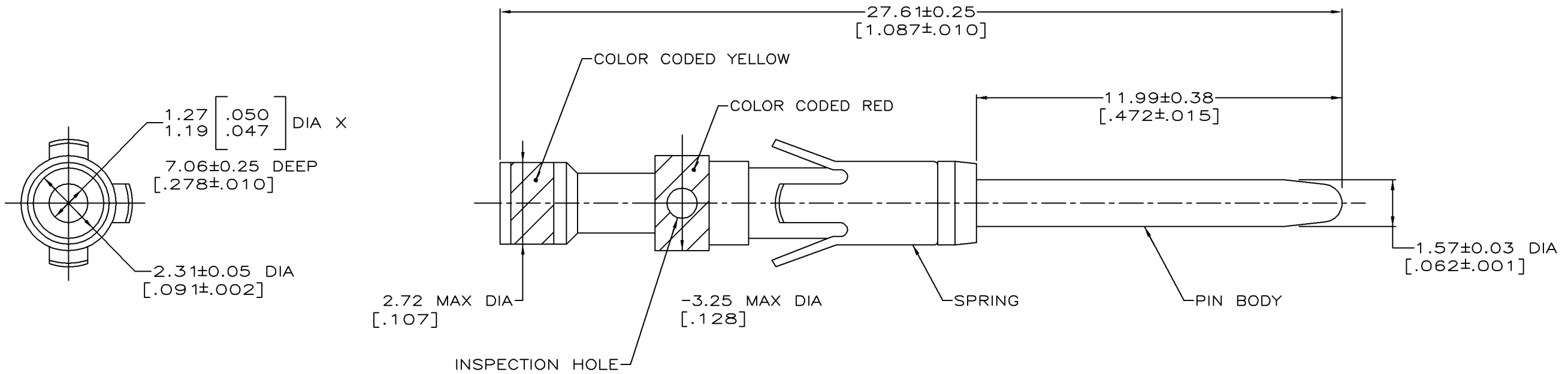

TAPE MTG DETAIL
SCALE 2:1

- ① 0.76µm [.000030] MIN GOLD OVER 1.27µm [.000050] MIN NICKEL.
- ② WHEN ORDERING CONTACT ASSEMBLY ON TAPE, ORDER BY THE TAPE NUMBER PLUS THE PACKAGING CODE AS FOLLOWS:
 1. FOR USE WITH AMP TAPETRONIC, PNEUMATIC TOOL-
 - A. 1000 PARTS TO A BOX ADD PACKAGING CODE: 1MBOX
 2. FOR USE WITH 4/8 INDENT STRIPPER CRIMPER-
 - A. 1000 PARTS TO A REEL ADD PACKAGING CODE: 1MREEL
 - B. 5000 PARTS TO A REEL ADD PACKAGING CODE: 5MREEL
- ③ OBSOLETE PARTS: OBSOLETE CIS STREAMLINING PER D.RENAUD/D.SINISI

③ OBSOLETE	SMALL PACK	201330-7-
	TAPE MTG (SEE DETAIL) ②	201330-6
	STANDARD	201330-1
	PACKAGING TYPE	PART NO

DO NOT SCALE PRINT. UNLESS SPECIFIED DIMENSIONS IN mm [INCHES] TOLERANCES ON : 2 PLC DEC ± - 3 PLC DEC ± - ANGLES ± -	DR 04/06/93 D.GELTZ	AMP AMP Incorporated Harrisburg, PA 17105-3608	
	CHK 4-26-93 R.STONE		
MATERIAL	APPD 4-29-93 R.S.KLINE	NAME	
PIN BODY: COPPER ALLOY SPRING: STAINLESS STEEL	APPD - PRODUCT SPEC -	CONTACT ASSEMBLY, PIN, #6, 20-24 AWG, TYPE II	
FINISH	APPLICATION SPEC -	SIZE	CAGE CODE
PIN BODY: ①	-	©	00779
	WEIGHT -	DRAWING NO	©=201330
		SCALE	SHEET
		10:1	1 OF 1

THIS DRAWING IS A CONTROLLED DOCUMENT FOR AMP INCORPORATED. IT IS SUBJECT TO CHANGE AND THE CONTROLLING ENGINEERING ORGANIZATION SHOULD BE CONTACTED FOR THE LATEST REVISION.