

REV.	DESCRIPTION	DATE	APPROVED
G	Engineering Update w/o Changes	03/01/04	M. C.
H	Changed "C" Dimensions for SW-XXX-145	06/21/07	M. C.
J	Removed Obsolete Products	06/19/09	T. Y.
K	Removed Obsolete Products	10/08/09	T. Y.
M	Removed Material Code	05/28/16	J. C.

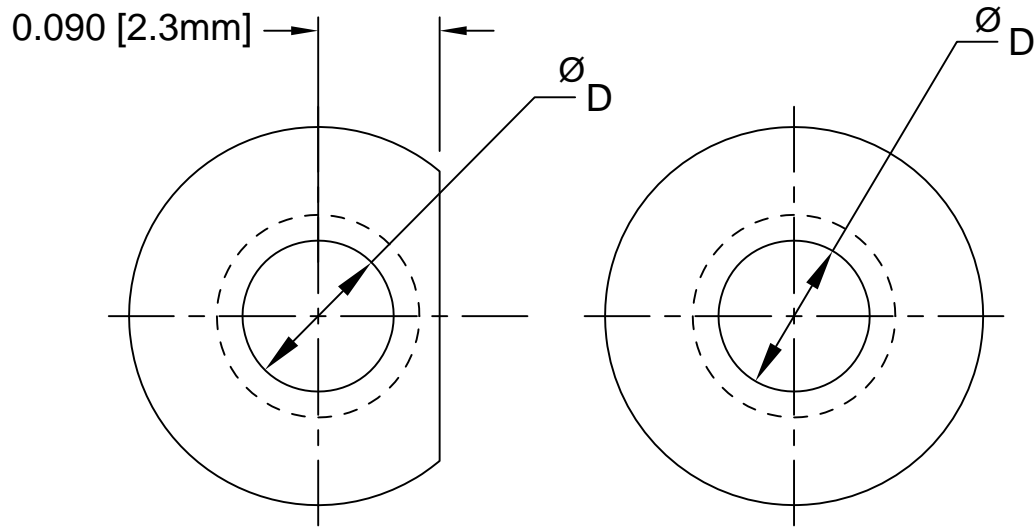
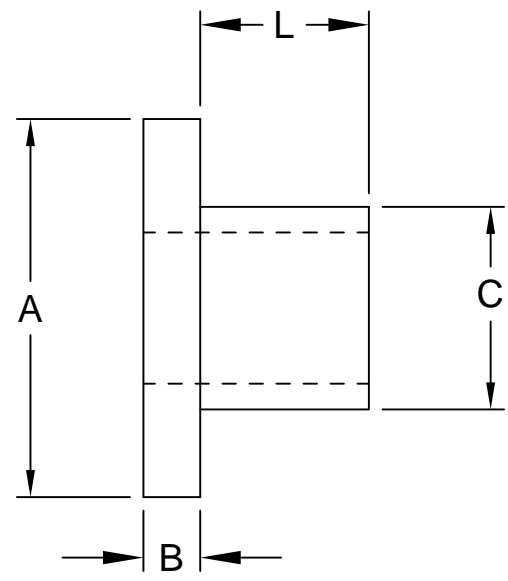

FIG. 2

FIG. 1



PART NO.	L	A	B	C	D	SCREW SIZE	FIG.	MATERIAL
SW-032-135	0.032(0.8mm)	0.215(5.5mm)	0.040(1.0mm)	0.130(3.3mm)	0.116(3.0mm)	4	1	1
SW-040-140	0.040(1.0mm)	0.245(6.2mm)	0.040(1.0mm)	0.140(3.6mm)	0.119(3.0mm)		2	
SW-125-140	0.125(3.2mm)	0.280(7.1mm)	0.042(1.1mm)	0.140(3.6mm)	0.112(2.8mm)		1	2
SW-031-145	0.031(0.8mm)	0.280(7.1mm)	0.047(1.2mm)	0.145(3.7mm)	0.118(3.0mm)			
SW-093-145	0.093(2.4mm)	0.235(6.0mm)	0.047(1.2mm)	0.140(3.6mm)	0.115(2.9mm)	6	1	1
SW-187-145	0.187(4.8mm)							
SW-125-150	0.125(3.2mm)	0.280(7.1mm)	0.042(1.1mm)	0.150(3.8mm)	0.112(2.8mm)			
SW-185-150	0.185(4.7mm)	0.280(7.1mm)	0.042(1.1mm)	0.150(3.8mm)	0.122(3.1mm)			
SW-031-177	0.031(0.8mm)	0.312(7.9mm)	0.047(1.2mm)	0.177(4.5mm)	0.144(3.7mm)	1	1	
SW-031-190	0.031(0.8mm)	0.312(7.9mm)	0.047(1.2mm)	0.190(4.8mm)	0.146(3.7mm)			

3. MATERIAL 2: NYLON 6/6, 94V-0, BLACK.
2. MATERIAL 1: POLYPHENYLENE SULFIDE, 40% GLASS FILLED, 94V-0, BLACK.
1. GENERAL SPECIFICATIONS: BIVAR MOLDED COMPONENT SPECIFICATION BV00-E101.

STANDARD TOLERANCE (UNLESS OTHERWISE SPECIFIED)		 4 THOMAS, IRVINE, CA. 92618 TEL: (949) 951-8808 FAX: (949) 951-3974	
DECIMALS	ANGULAR		
.X ±.1	X° ± 1°	 TITLE: HIGH TEMPERATURE SHOULDER WASHER	
.XX ±.01			
.XXX ±.005			
DESIGNED: D. Green	DATE: 01/17/03	PART NO: SW-XXX-XXX	REVISION: M
CHECKED: M. Chen	DATE: 01/17/03	CAGE CODE : 32559	SHEET # 1 OF 1
CAD GENERATED DOCUMENT. DO NOT MEASURE DRAWING.			