

| REVISIONS |      |     |                            |         |     |      |
|-----------|------|-----|----------------------------|---------|-----|------|
| REV       | ZONE | ECO | DESCRIPTION                | DATE    | BY  | APPR |
| 02        | --   | --  | UPDATE CONTACT PART NUMBER | 06MAR12 | --  | RFC  |
| 03        | --   | --  | UPDATE DRAWING FORMAT      | 06NOV13 | DRP | DRP  |

NOTES: UNLESS OTHERWISE SPECIFIED

- ① DIMENSIONS ARE FOR REFERENCE ONLY.
- ② PART NUMBER AT04-3P-RJ120BK IS FULLY ASSEMBLED READY FOR INSTALLATION.
- ③ COLOR TO BE SINE SYSTEMS STANDARD 'AT' BLACK.

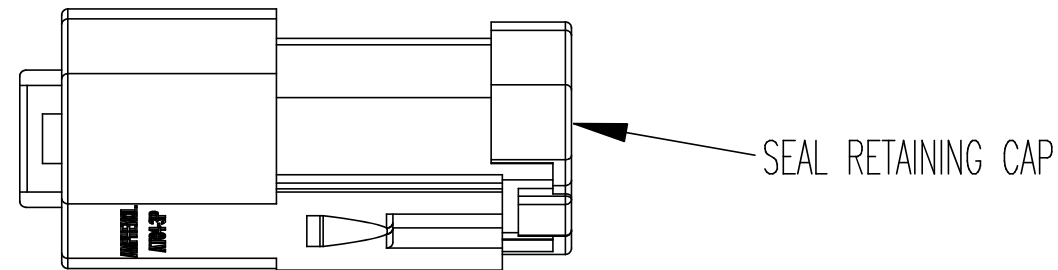

SEAL RETAINING CAP

LASER MARK "R120"  
RESISTOR VALUE

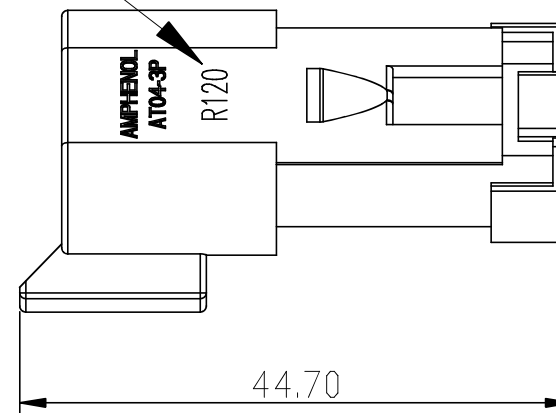

REAR SOLID SEAL

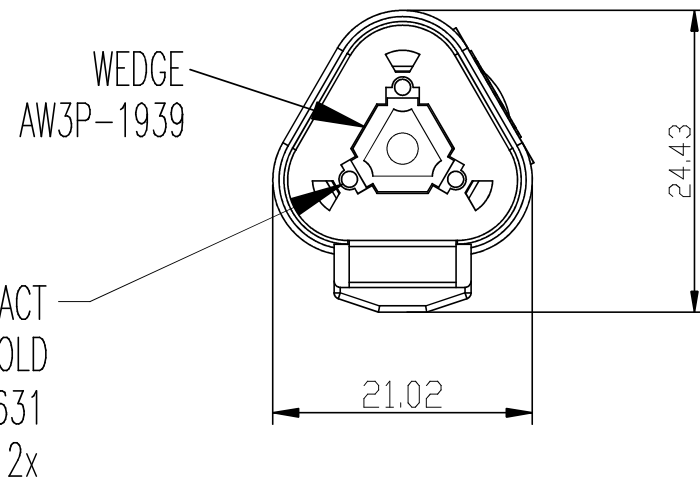
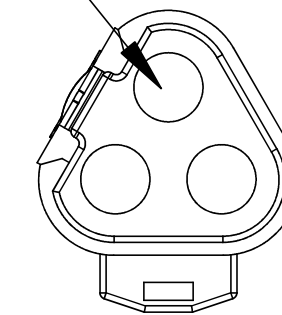

MALE CONTACT  
MACHINED, GOLD  
AT60-202-1631  
2x

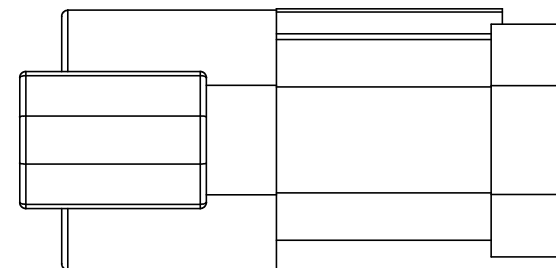

WIRING DIAGRAM

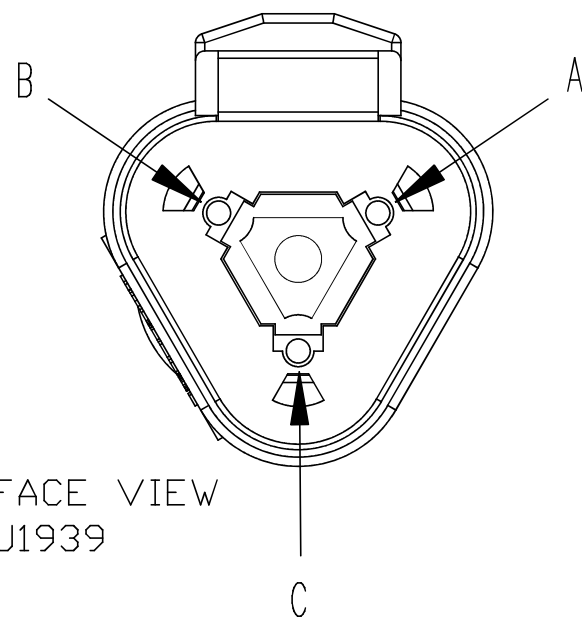

FACE VIEW  
J1939

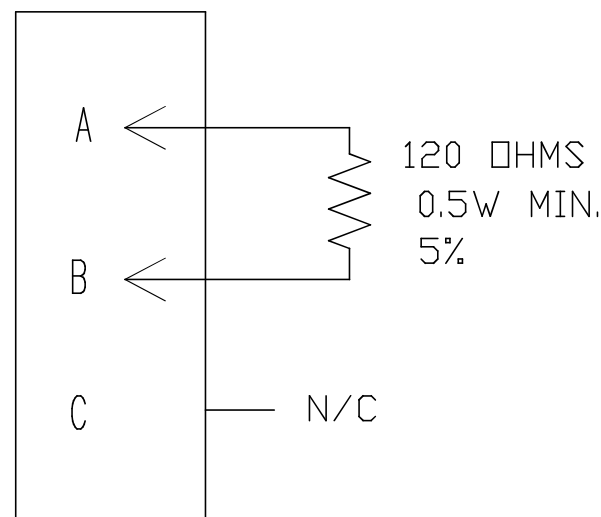

**CUSTOMER DRAWING**

| ITEM  | PART NUMBER | Qty             | DESCRIPTION  | REMARK  |       |
|---|-------------|-----------------|--|---|-------|
| <b>MATERIALS LIST</b>   |             |                 |  |   |       |
| UNLESS OTHERWISE SPECIFIED<br>1) All dimensions are in metric(mm).<br>2) Tolerances are as follows:<br>1 PL DEC ±0.20<br>2 PL DEC ±0.10<br>3 PL DEC ±0.05 |             |                 | MATERIAL SPECIFICATIONS:   | <b>SINE Systems Corporation</b><br>A Subsidiary of Amphenol Corporation |       |
| Fractions ±1/64<br>Angles ±1°   |             |                 | PROCESS SPECIFICATIONS:<br>IPC-A-620   |   |       |
| SIGNATURE   |             | DATE            | THIS DRAWING IS SUPPLIED FOR INFORMATION ONLY. DESIGN FEATURES, SPECIFICATIONS AND PERFORMANCE DATA SHOWN HEREON ARE THE PROPERTY OF THE AMPHENOL CORPORATION. NO RIGHTS OF REPRODUCTION ARE IMPLIED. ALL DIMENSIONS ARE SUBJECT TO NORMAL MANUFACTURING VARIATIONS. |   |       |
| DRAWN   | R. CURRY    | 02-MAR-12       |  |   |       |
| CHECKED   | R. CURRY    | 02-MAR-12       |  |   |       |
| ENGINEER  | R. CURRY    | 02-MAR-12       |  |   |       |
| APPROVAL  | R. CURRY    | 02-MAR-12       |  |   |       |
| CUSTOMER  | ALL         |                 |  |   |       |
| DWG NO.   |             | AT04-3P-RJ120BK |  |   |       |
| THIRD ANGLE PROJECTION  | FSCM NO.    | SIZE            | MASS   | REV.  | SCALE |
|   |             | A3              |  | 03  | NONE  |
| SHEET 1 OF 1  |             | NEXT ASSY:      |  |   |       |