

## SMD LED in PLCC-2 Package

### Description

This device has been redesigned in 1998 replacing SiC by GaN technology to meet the increasing demand for high efficiency blue LEDs.

The package of the TLMB310. is the PLCC-2 (equivalent to a size B tantalum capacitor).

It consists of a lead frame which is embedded in a white thermoplast. All LEDs are categorized in luminous intensity groups. That allows users to assemble LEDs with uniform appearance.

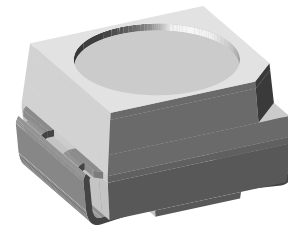

19225



### Features

- GaN on SiC technology
- EIA and ICE standard package
- Compatible with infrared, vapor phase and wave solder processes according to CECC
- Available in 8 mm tape
- Non-diffused lens: excellent for coupling to light pipes and backlighting
- Luminous intensity ratio in one packaging unit  
 $I_{Vmax}/I_{Vmin} \leq 1.6$
- ESD class 1
- Lead-free device

### Applications

Automotive:

Backlighting in dashboards and switches

Telecommunication:

Indicator and backlighting in telephone and fax

Indicator and backlight for audio and video equipment

Indicator and backlight in office equipment

Flat backlight for LCDs, switches and symbols

General use

### Parts Table

Part	Color, Luminous Intensity	Angle of Half Intensity ( $\pm\phi$ )	Technology
TLMB3100	Blue, $I_V > 4.0$ mcd	60 °	GaN on SiC
TLMB3101	Blue, $I_V = (4.0$ to 12.5)	60 °	GaN on SiC
TLMB3104	Blue, $I_V = (5.0$ to 12.5)	60 °	GaN on SiC
TLMB3106	Blue, $I_V = (5.0$ to 20.0)	60 °	GaN on SiC

### Absolute Maximum Ratings

$T_{amb} = 25$  °C, unless otherwise specified

#### TLMB310.

Parameter	Test condition	Symbol	Value	Unit
Reverse voltage		$V_R$	5	V
DC Forward current	$T_{amb} \leq 60$ °C	$I_F$	20	mA
Surge forward current	$t_p \leq 10$ $\mu$ s	$I_{FSM}$	0.1	A
Power dissipation	$T_{amb} \leq 60$ °C	$P_V$	100	mW
Junction temperature		$T_j$	100	°C
Operating temperature range		$T_{amb}$	- 40 to + 100	°C

Parameter	Test condition	Symbol	Value	Unit
Storage temperature range		$T_{stg}$	- 40 to + 100	°C
Soldering temperature	$t \leq 5$ s	$T_{sd}$	260	°C
Thermal resistance junction/ambient	mounted on PC board (pad size > 16 mm <sup>2</sup> )	$R_{thJA}$	400	K/W

### Optical and Electrical Characteristics

$T_{amb} = 25$  °C, unless otherwise specified

### Blue

#### TLMB310.

Parameter	Test condition	Part	Symbol	Min	Typ.	Max	Unit
Luminous intensity <sup>1)</sup>	$I_F = 10$ mA	TLMB3100	$I_V$	4.0	8.0		mcd
		TLMB3101	$I_V$	4.0		12.5	mcd
		TLMB3104	$I_V$	5.0		12.5	mcd
		TLMB3106	$I_V$	5.0		20.0	mcd
Dominant wavelength	$I_F = 10$ mA		$\lambda_d$		466		nm
Peak wavelength	$I_F = 10$ mA		$\lambda_p$		428		nm
Angle of half intensity	$I_F = 10$ mA		$\phi$		$\pm 60$		deg
Forward voltage	$I_F = 20$ mA		$V_F$		3.9	4.5	V
Reverse voltage	$I_R = 10$ $\mu$ A		$V_R$	5			V

<sup>1)</sup> in one Packing Unit  $I_{Vmax}/I_{Vmin} \leq 1.6$

### Typical Characteristics ( $T_{amb} = 25$ °C unless otherwise specified)

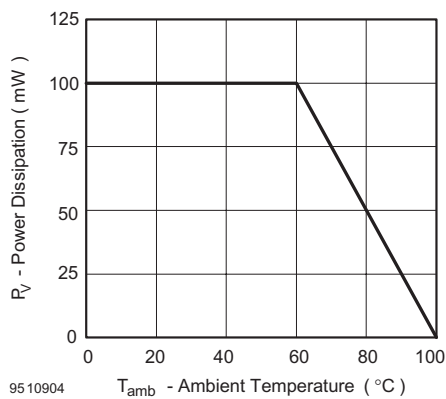

Figure 1. Power Dissipation vs. Ambient Temperature

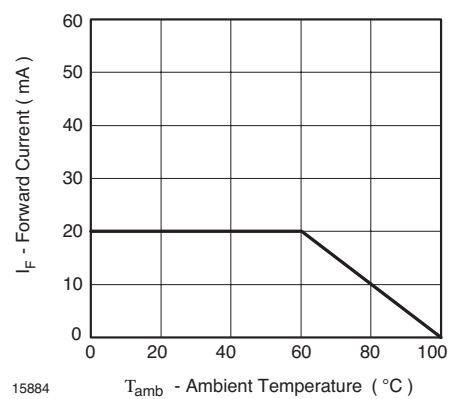
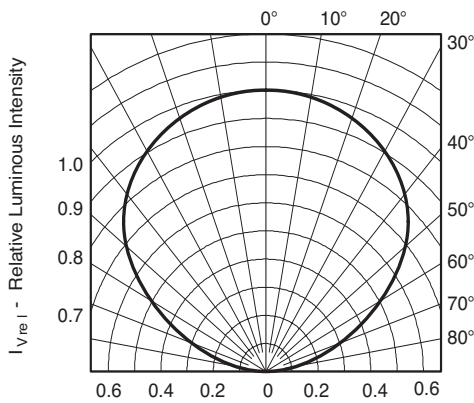
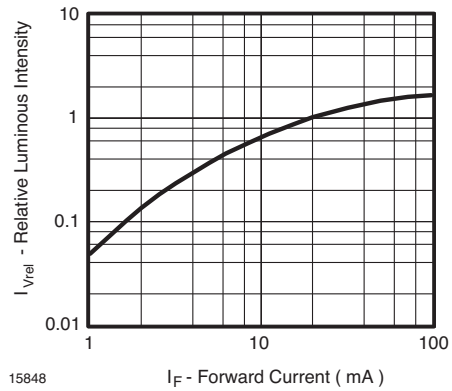

Figure 2. Forward Current vs. Ambient Temperature for InGaN



95 10319

Figure 3. Rel. Luminous Intensity vs. Angular Displacement



15848

Figure 6. Relative Luminous Flux vs. Forward Current

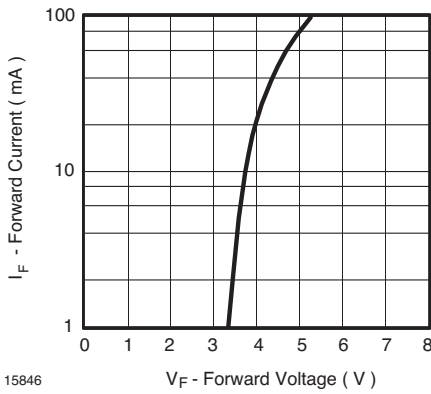

15846

Figure 4. Forward Current vs. Forward Voltage

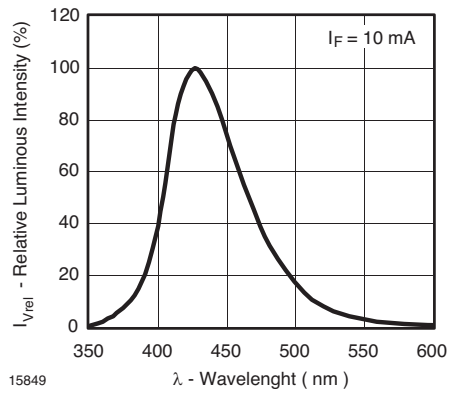

15849

Figure 7.

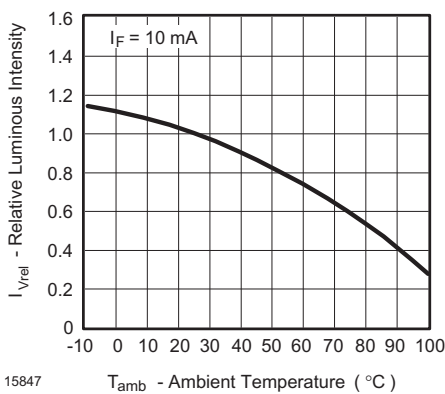

15847

Figure 5. Rel. Luminous Flux vs. Ambient Temperature

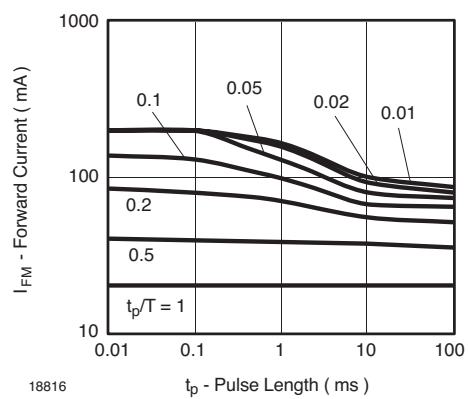

18816

Figure 8. Forward Current vs. Pulse Length

### Package Dimensions in mm

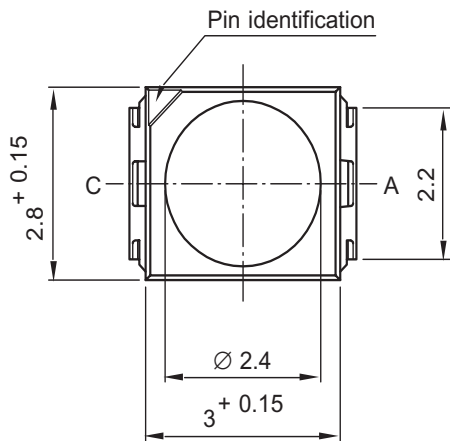
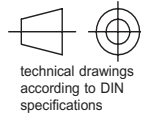
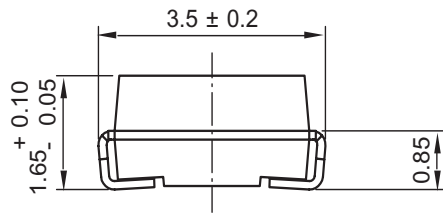

### Mounting Pad Layout

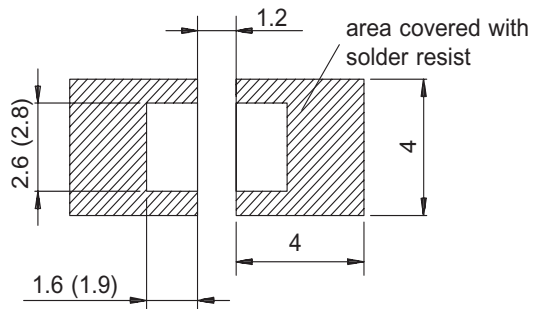

Dimensions: IR and Vaporphase  
(Wave Soldering)

Drawing-No. : 6.541-5025.01-4  
Issue: 7; 05.04.04

95 11314

## **Ozone Depleting Substances Policy Statement**

It is the policy of **Vishay Semiconductor GmbH** to

1. Meet all present and future national and international statutory requirements.
2. Regularly and continuously improve the performance of our products, processes, distribution and operating systems with respect to their impact on the health and safety of our employees and the public, as well as their impact on the environment.

It is particular concern to control or eliminate releases of those substances into the atmosphere which are known as ozone depleting substances (ODSs).

The Montreal Protocol (1987) and its London Amendments (1990) intend to severely restrict the use of ODSs and forbid their use within the next ten years. Various national and international initiatives are pressing for an earlier ban on these substances.

**Vishay Semiconductor GmbH** has been able to use its policy of continuous improvements to eliminate the use of ODSs listed in the following documents.

1. Annex A, B and list of transitional substances of the Montreal Protocol and the London Amendments respectively
2. Class I and II ozone depleting substances in the Clean Air Act Amendments of 1990 by the Environmental Protection Agency (EPA) in the USA
3. Council Decision 88/540/EEC and 91/690/EEC Annex A, B and C (transitional substances) respectively.

**Vishay Semiconductor GmbH** can certify that our semiconductors are not manufactured with ozone depleting substances and do not contain such substances.

**We reserve the right to make changes to improve technical design  
and may do so without further notice.**

Parameters can vary in different applications. All operating parameters must be validated for each customer application by the customer. Should the buyer use Vishay Semiconductors products for any unintended or unauthorized application, the buyer shall indemnify Vishay Semiconductors against all claims, costs, damages, and expenses, arising out of, directly or indirectly, any claim of personal damage, injury or death associated with such unintended or unauthorized use.

Vishay Semiconductor GmbH, P.O.B. 3535, D-74025 Heilbronn, Germany  
Telephone: 49 (0)7131 67 2831, Fax number: 49 (0)7131 67 2423



### Notice

Specifications of the products displayed herein are subject to change without notice. Vishay Intertechnology, Inc., or anyone on its behalf, assumes no responsibility or liability for any errors or inaccuracies.

Information contained herein is intended to provide a product description only. No license, express or implied, by estoppel or otherwise, to any intellectual property rights is granted by this document. Except as provided in Vishay's terms and conditions of sale for such products, Vishay assumes no liability whatsoever, and disclaims any express or implied warranty, relating to sale and/or use of Vishay products including liability or warranties relating to fitness for a particular purpose, merchantability, or infringement of any patent, copyright, or other intellectual property right.

The products shown herein are not designed for use in medical, life-saving, or life-sustaining applications. Customers using or selling these products for use in such applications do so at their own risk and agree to fully indemnify Vishay for any damages resulting from such improper use or sale.